

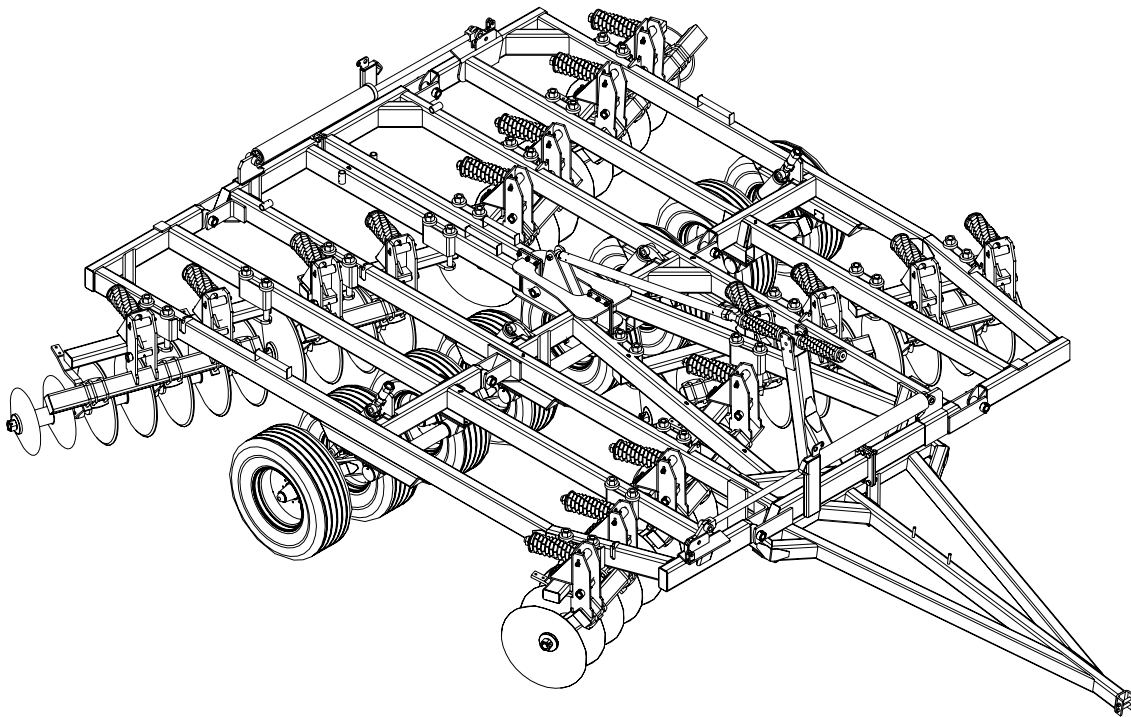

# 800NT SERIES TANDEM DISC



**O  
P  
E  
R  
A  
T  
O  
R  
S  
M  
A  
N  
U  
A  
L**



112 South 2nd Street  
Wishek, ND 58495  
701-452-2449  
[www.wishekmfg.com](http://www.wishekmfg.com)

## **WISHEK WARRANTY PROGRAM**

Dealer or distributor understands and agrees that Manufacturer extends only the following warranty to customers. In the event Dealer or Distributor extends any additional warranty (such as by enlarging the scope or period of warranty or undertaking a warranty of merchantability or fitness for any particular purpose) or any other obligation whatsoever, Dealer or Distributor shall: (1) be solely responsible therefore; (2) have no recourse against Manufacturer thereof and (3) defend, indemnify and hold Manufacturer harmless against any claim or cause of action whatsoever arising out of, or occasioned by, Dealer or Distributor's extension of said additional warranty or obligation.

### **CERTIFICATE OF GENERAL EQUIPMENT WARRANTY**

Wishek Mfg. L.L.C warrants new products sold by it to be free from defects in material or workmanship for a period of one (1) year after date of delivery to the first user and subject to the following conditions. Wishek Mfg. L.L.C. obligation and liability under this warranty is expressly limited to repairing or replacing at Wishek Mfg. L.L.C. option any parts that appear to Wishek Mfg. L.L.C. upon inspection to have been defective in material or workmanship. Such parts shall be provided at no cost to user, at the business establishment of the authorized Wishek Mfg. L.L.C. dealer or distributor of the product during regular business hours. This warranty shall not apply to component parts or accessories of products not manufactured by Wishek Mfg. L.L.C. and which carry the warranty of the manufacturer thereof, or to normal maintenance (such as tune up) or to normal maintenance parts (such as oil filters). Replacement or repair parts installed in the product covered by this warranty are warranted only for the remainder of this warranty as if such parts were original of said product. **WISHEK MFG. MAKES NO OTHER WARRANTY, EXPRESSED OR IMPLIED, AND MAKES NO WARRANTY OF MERCHANTABILITY OR FITNESS FOR ANY PARTICULAR PURPOSE.**

Wishek Mfg. L.L.C. obligation under this warranty shall not include any transportation charges, cost of installation, duty taxes or any other charges whatsoever, or any liability for direct, indirect, incidental, or consequential damage or delay. If requested by Wishek Mfg. L.L.C. products or parts for which warranty claim is made are to be returned transportation prepaid to Wishek Mfg. L.L.C. Any improper use, including operation after discovery of defective or worn parts, operation beyond rated capacity, substitution or parts not approved by Wishek Mfg. L.L.C. or any alteration or repair by others in such a manner as in Wishek Mfg. L.L.C. judgement affects the product materially and adversely, shall void this warranty.

**NO EMPLOYEE OR REPRESENTATIVE IS AUTHORIZED TO CHANGE THIS WARRANTY IN ANY WAY OR GRANT ANY OTHER WARRANTY UNLESS SUCH CHANGE IS MADE IN WRITING, AND SIGNED BY AN OFFICER OF WISHEK MFG. L.L.C. AT ITS HOME OFFICE.**

### **LIABILITY FOR DELAYS**

No liability shall attach to Manufacturer for direct, indirect, incidental or consequential damages or expenses due to loss, damage, detention or delays in delivery of products resulting from acts or delays beyond its control.

### **WARRANTY CLAIMS AND RETURN OF GOODS:**

1. The dealer shall submit each warranty claim to the Company within 30 days after the defective part has been replaced.
2. The dealer shall furnish the company definite proof of delivery date of the machine to the purchaser prior to the Company's honoring any warranty claim.
3. All parts alleged to be defective under the Company's warranty policy shall be made available for examination by the Company, either at the dealer's place of business or factory of the Company, at the Company's option. If examination is to be at the factory, the part shall be returned to the Company with transportation charge prepaid only after the dealer receives specific shipping instructions from the Company.
4. Goods authorized for return to the factory are to be returned by dealer within 30 days from authorization date. Failure to return within 30-day period will invalidate the warranty claim.

In order to be protected under the terms of the Warranty or Wishek Manufacturing L.L.C., and to avoid delay in processing warranty claims, the original owners name, address and identification numbers of the machine should be registered at the office of Wishek Mfg. L.L.C. within 30 days from from the date of purchase. A registration card is furnished with each machine and can be found on the last page of this booklet.

# **CONTENTS**

TO THE OWNER .....	5
GENERAL INFORMATION .....	6-7
SIGNOFF FORM .....	8
TRACTOR REQUIREMENTS .....	9
SAFETY .....	10-13
SPECIFICATIONS .....	14-15
DECALS .....	16-17
GENERAL OPERATING	
INSTRUTIONS.....	18-19
TOWING .....	20
TRANSPORT LOCKOUT .....	20
WING LIFT CIRCUITRY .....	21
DEPTH CONTROL CIRCUITRY .....	22-23
FRONT WING LOCKOUT .....	24
LEVELING AND SCRAPER ADJUST. ..	25
FIELD SETTING .....	26
MAINTINENCE/LUBRICATION .....	27-28
GANG BEARINGS .....	29
WHEEL BEARING .....	30-31
STORAGE.....	32
TROUBLE SHOOTING.....	33
ASSEMBLY INSTRUCTIONS .....	34-48
BEARING STAND ALIGNMENT .....	49
GANG ASSEMBLY .....	50-51
GANG PLACEMENT .....	51-59
SCRAPER BLADE ASSEMBLY .....	60-63
HAZARD LIGHT PLACEMENT .....	64

# PERSONAL SAFETY IS IMPORTANT!

ALL PERSONNEL INVOLVED WITH THE ASSEMBLY AND/OR OPERATION OF THIS EQUIPMENT MUST BE INFORMED OF PROPER SAFETY PROCEDURES. OPERATOR'S/ASSEMBLY MANUALS PROVIDE THE NECESSARY INFORMATION. IF THE MANUAL IS LOST FOR A PARTICULAR IMPLEMENT, ORDER A REPLACEMENT AT ONCE. OPERATOR'S AND ASSEMBLY MANUALS ARE AVAILABLE AT NO CHARGE UPON REQUEST.

This Safety Alert symbol means **ATTENTION!**  
**BECOME ALERT YOUR SAFETY IS INVOLVED!**

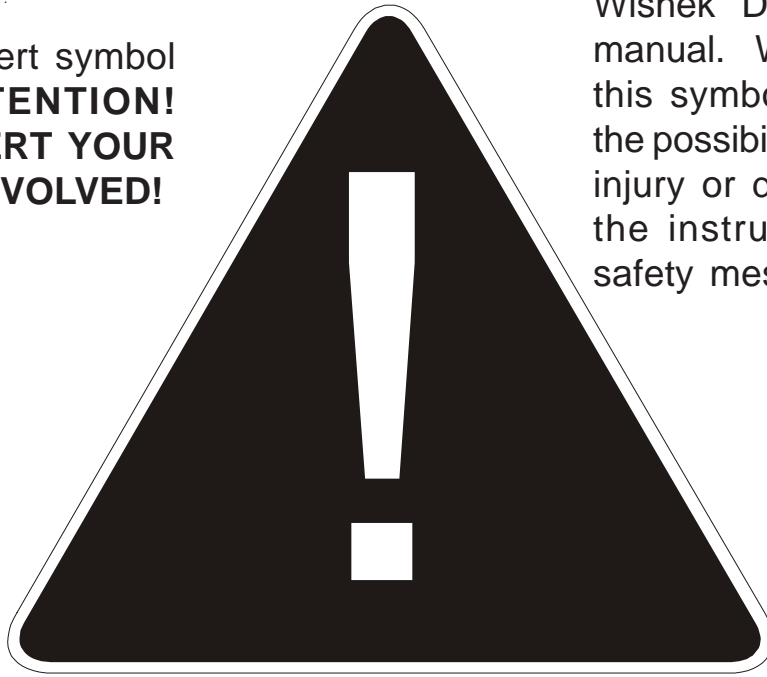

The Safety Alert symbol identifies important safety messages on your Wishek Disc and in this manual. When you see this symbol, be alert to the possibility of personal injury or death. Follow the instructions in the safety message.

## Why is SAFETY important to you?

3 Big Reasons

Accidents Disable and Kill

Accidents Cost

Accidents Can Be Avoided

### SIGNAL WORDS:

Note the use of the signal words **DANGER**, **WARNING** and **CAUTION** with the safety messages. The appropriate signal word for each message has been selected using the following guidelines:

### DANGER

An immediate and specific hazard which **WILL** result in severe personal injury or death if the proper precautions are not taken.

### WARNING

A specific hazard or unsafe practice which **COULD** result in severe personal injury or death if the proper precautions are not taken

### CAUTION

Unsafe practices which **COULD** result in personal injury if proper practices are not taken, or as a reminder of good safety practices.

## TO THE OWNER

It is the responsibility of the user to read the Operator's Manual and comply with the safe and correct operating procedures as pertains to the operation, lubrication and maintenance of the product according to the information outlined in the Operator's Manual.

If this machine is used by an employee or is loaned or rented, make certain that the operator(s), prior to operating, is instructed in safe and proper use and reviews and understands the Operator's Manual.

The user is responsible for inspecting his/her machine and for having parts repaired or replaced when continued use of this product would cause damage or excessive wear to the other parts. The word NOTE is used to convey information that is out of context with the manual text; special information such as specifications, techniques, reference information of supplementary nature.

### **MODIFICATIONS**

It is the policy of **WISHEK** to improve its products whenever possible and practical to do so. We reserve the right to make changes, improvements and modifications at any time without incurring obligation to make such changes, improvements on any equipment sold previously.



**THIS SYMBOL USED TO CALL YOUR ATTENTION TO INSTRUCTIONS CONCERNING YOUR PERSONAL SAFETY. BE SURE TO OBSERVE AND FOLLOW THESE INSTRUCTIONS**

	<b>WISHEK MFG.</b>
	WISHEK, NORTH DAKOTA 58495 U.S. PATENT NO. 4396070 CANADIAN PAT. NO. 1181979 PATENTED 1985
<b>MODEL</b> _____	
<b>SERIAL NO.</b> _____	

When in need of parts, always specify the model and serial number. Write this number in the space provided. The serial number plate is located on the main frame front face in the front left corner.

### **PREPARATION**

Before operating the **WISHEK 800NT Series Disc**, a careful inspection must become routine. A check must be made to ensure that all hardware and fasteners are securely tightened and moving parts properly lubricated.

Remove all wires and/or banding material. The parts have been conveniently arranged on the pallet for ease of assembly.

**NOTE:** Always wear safety glasses or goggles and be careful when cutting wires and steel bands as they are under tension and will spring back when cut.

Wherever the terms "left" and "right" are used, it must be understood to mean from a position behind and facing the machine.

Lubricate all bearings and moving parts as you proceed and make sure they work freely.

# **GENERAL INFORMATION**

## **FASTENERS**

Loosely install all bolts connecting mating parts before final tightening.

When tightening bolts, they must be torqued to the proper number of foot-pounds as indicated in the table unless specified. It is important that all bolts be kept tight.

On new machines, all nuts and bolts must be rechecked after a few hours of operation.

When replacing a bolt, use only a bolt of the same grade or higher. Except in shear bolt applications, where you must use the same grade bolt.

Bolts with no markings are grade 2

Grade 5 bolts furnished with the machine are identified by three radial lines on the head.



Grade 8 bolts furnished with the machine are identified by six radial lines on the head.

All U-bolts are grade 5.

## **TIRE INFLATION**

The use of proper air pressure is the most important factor in satisfactory performance and maintenance of implement tires. Underinflation will damage the cord body of the tire and cause a series of diagonal breaks in the fabric sidewall area.

If the tire buckles or wrinkles, the air pressure must be increased to the point where the sidewall remains

	GRADE 2		GRADE 5		GRADE 8	
						
<b>TORQUE IN FOOT POUNDS</b>						
BOLT DIA	3/8	1/2	5/8	3/4	7/8	1
HEX HEAD	9/16	3/4	15/16	1-1/8	1-5/16	1-1/2
UNC GR2	18	45	89	160	252	320
UNC GR5	30	68	140	240	360	544
UNC GR8	40	100	196	340	528	792
UNF GR2	21	51	102	178	272	368
UNF GR5	32	70	168	264	392	572
UNF GR8	48	112	216	368	792	840

Note: Do not inflate tires beyond the specified tire pressure.

## **WHEEL BOLTS**

It is recommended that all wheel bolts be checked for tightness before using and again after one day of use. Check periodically to be sure the wheel bolts are tight.

## **LUBRICATION**

Make sure the disc is properly lubricated. See pages 28-30.

## **HYDRAULICS**

Check wing lift and depth control cylinders for proper alignment and operation. On any machine, check that the hydraulic system has been properly charged and purged.



Remove all wires and/or banding material. The parts have been conveniently arranged on the pallet for ease of assembly.

NOTE: Always wear safety glasses or goggles and be careful when cutting wires and steel bands as they are under tension and will spring back when cut.

Wherever the terms "left" and "right" are used, it must be understood to mean from a position behind and facing the machine.

Lubricate all bearings and moving parts as you proceed and make sure they work freely.

Loosely install all bolts connecting mating parts before final tightening.

When tightening bolts, they must be torqued to the proper number of foot-pounds as indicated in the table unless specified. It is important that all bolts be kept tight. (See Page 6)

On new machines, all nuts and bolts must be rechecked after a few hours of operation.

When replacing a bolt, use only a bolt of the same grade or higher. Except in shear bolt applications, where you must use the same grade bolt.

Bolts with no markings are grade 2

Grade 5 bolts furnished with the machine are identified by three radial lines on the head.

Grade 8 bolts furnished with the machine are identified by six radial lines on the head.

All U-bolts are grade 5.



THIS SYMBOL USED TO CALL YOUR ATTENTION TO INSTRUCTIONS CONCERNING YOUR PERSONAL SAFETY.

BE SURE TO OBSERVE AND FOLLOW THESE INSTRUCTIONS



## CAUTION

FAILURE TO FOLLOW THESE INSTRUCTIONS MAY RESULT IN PERSONAL INJURY AND/OR EQUIPMENT DAMAGE.

- Just before and during operation be sure no one is on or around the implement.
- Before activating the hydraulic system, check hoses for proper connections.
- Before lowering the wings for the first time, make sure the entire system has been charged with oil.
- With wings down always install hydraulic cylinder channel lock(s) for transporting.

49165

# **SIGN-OFF FORM**

**WISHEK** follows the general standard specified by the American Society of Agricultural and Biological Engineers (ASABE) and the Occupational Safety and Health Administration (OSHA). Anyone who will be operating and/or maintaining the 800NT Disc must read and understand ALL Safety, Operation, and Maintenance information presented in this manual.

Do not operate or allow anyone else to operate this equipment until such information is reviewed. Annually review this information before the season start-up.

Make periodic reviews of SAFETY and OPERATION a standard practice for all your equipment. We feel that an untrained operator is unqualified to operate this machine.

A sign-off sheet is provided for all personnel who will be working with equipment have read and understood the information in the operators manual and have been instructed in the operation of the equipment.

<b>DATE</b>	<b>EMPLOYEE'S SIGNATURE</b>	<b>EMPLOYER'S SIGNATURE</b>



---

# TRACTOR REQUIREMENTS

---

The **WISHEK** Disc requires approximately 12-16 horsepower per foot. One remote cylinder outlet and control is required for non-winged units. Two remotes are required for winged units.

## WHEELS AND TIRES

Dual tractor rear wheels are recommended for use with the disc. See your tractor's operator's manual for tire inflation and instructions for wheel ballast where required.

## METERING VALVES

The metering valve may be set to provide varying amounts of hydraulic oil flow to the cylinders (see your tractor operator's manual.)

It is recommended the wing lift cylinders run as slow as possible to prevent damage to the implement, persons and property. Turn wing lift hydraulics metering valves to slow position.

## FRONT BALLAST

Tractor front end stability is necessary for safe and efficient operation. Therefore, it is important that the proper amount of weight be installed on the front of the tractor as recommended in your tractor operator's manual.



**Note:** Ballast recommendations provide for adequate transport stability at recommended speeds. Additional front ballast may be required for satisfactory field operation due to sudden or extreme forces on the tandem disc. These forces may occur when removing the disc from the ground and turning at rows end, or during field transport over very rough ground.

## TRANSPORTING

A SMV (Slow Moving Vehicle) emblem **must** be used at all times while traveling on public roads.

The implement must always be placed in transport position and the cylinder channel locks used when traveling on public roads. Never depend on your tractor's hydraulic system to carry the weight while transporting.



**Note:** Use extreme caution when working around overhead power transmission lines.

**Note:** Always install lock channels in the center frame lift cylinders for road transport.

Reduce speed when cornering and when traveling over rough and/or uneven ground. Drive at a reasonable speed to maintain complete control of the machine at all times.

Comply with your state and local laws governing highway safety when moving machinery on a highway.

## BEARING ASSEMBLIES

**IMPORTANT:** The spindle nuts on the wheel assemblies are preset at the factory.

Road transport and field working will seat the bearings and will require additional adjustment. After 20 hours of machine operation remove the grease cap and check the bearing tightness.

Remove the cotter pin and rotate the tire while tightening the spindle nut. Tighten until the drag on the tire stops the rotation. Locate the cotter pin hole in the spindle and loosen the spindle nut just enough to allow insertion of the cotter pin. Replace cotter pin and grease cap.

# **SAFETY**

**YOU are responsible for SAFE operation and maintenance of your Wishek Disc. YOU must ensure that anyone who is going to operate, maintain or work around the disc be familiar with the operating and maintenance procedures and related safety information contained in this manual. This manual will take you step by step through your working day, alerts you to all good safety practices that should be adhered to while operating this equipment.**



Remember, YOU are the key to safety. Good safety practices not only protect you but also the people around you. Make these practices a working part of your safety program. Be certain that EVERYONE operating this equipment is familiar with the recommended operating and maintenance procedures and follows all safety precautions. Most accidents can be prevented. Do not risk injury or death by ignoring good safety practices.

Disc owners must give operating instructions to operators and employees before allowing them to operate the disc, and at least annually thereafter per OSHA regulation 1928.57.

The most important safety device on this equipment is a safe operator. It is the operator's responsibility to read and understand ALL Safety and Operating instructions in the manual and to follow them. All accidents can be avoided.

A person who has not read and understood all operating and safety instructions is not qualified to operate the machine. An untrained operator exposes themselves and bystanders to possible serious injury or death.

Do not modify the equipment in any way. Unauthorized modifications may impair the function and/or safety and could affect the life of the equipment.

Think SAFETY! Work SAFELY!

## **GENERAL SAFETY BEFORE OPERATING**

Read and understand the operator's manual and all safety signs before operating, maintaining or adjusting the disc.

Review safety related items with all operators annually.

Use extreme care when making adjustments.

When working under or around the machine, always lower the disc to the ground.

After servicing, install and properly secure all shields and guards before operating. Remove all tools, parts, and service equipment from the machine.

Have a first-aid kit available for use should the need arise and know how to use it.

Have a fire extinguisher available for use should the need arise and know how to use it.

Clear the area of people and remove foreign objects from the machine before starting and operating.

Always wear relatively tight and belted clothing to avoid entanglement in moving parts. Wear sturdy, rough-soled work shoes and protective equipment for eyes, hair, hands, and head. Wear suitable ear protection for prolonged exposure to excessive noise.

Stop tractor engine, place all controls in neutral, set park brake, remove ignition key and wait for all moving parts to stop before servicing, adjusting, repairing or unplugging. Do not attempt to remove any obstruction while machine is in motion.

## HYDRAULIC SAFETY

Always place all tractor hydraulic controls in neutral before dismounting.

Make sure that all components in the hydraulic system are kept in good condition and are clean.



Relieve pressure before working on hydraulic system.

Replace any worn, cut, abraded, flattened or crimped hoses and metal lines.

Before applying pressure to the system, make sure all components are tight and that lines, hoses and couplings are not damaged.

Do not attempt any makeshift repairs to the hydraulic lines, fittings or hoses by using tape, clamps or cements. The hydraulic system operates under extremely high-pressure. Such repairs will fail suddenly and create a hazardous and unsafe condition.

Wear proper hand and eye protection when searching for high pressure leaks. Use a piece of cardboard as a backstop instead of hands to isolate and identify a leak.

If injured by a concentrated high-pressure stream of hydraulic fluid, seek medical attention immediately. Serious infection or toxic reaction can develop from hydraulic fluid piercing the skin surface.

## STORAGE SAFETY

Store unit in an area away from human activity.

Do not permit children to play around the stored unit.

Store in a dry, level area with wings folded down and transport locks installed. Support the base with planks if required.

## TIRE SAFETY

Failure to follow proper procedures when mounting a tire on a wheel or rim can produce an explosion which may result in serious injury or death.

Do not attempt to mount a tire unless you have the proper equipment and experience to do the job.

Have a qualified tire dealer or repair service perform required tire maintenance.

## TRANSPORT SAFETY

Read and understand ALL the information in the Operator's Manual regarding procedures and SAFETY when moving the disc in the field, yard or on the road.

Check with local authorities regarding transportation on public roads. Obey all applicable laws and regulations.

Always travel at a safe speed. Reduce speed and use caution when making corners or meeting traffic.

Make sure SMV (Slow Moving Vehicle) emblem and all lights and reflectors that are required by the local highway and transport authorities are in place, are clean and can be seen clearly by all overtaking and oncoming traffic

Use a drawbar pin with provisions for a mechanical retainer.

Attach a safety chain before moving (see safety chain information.)

Always transport with wing lock pins in and lift cylinder locks installed.

Always use hazard warning flashers on tractor when transporting unless prohibited by law.

Do not allow riders.

Do not exceed 20 m.p.h. during transport.

## SMV

The SMV emblem is to be secured as near to the rear and centered, or as near to the left center of the implement as possible.

The bracket provided is designed to mount to numerous frame sizes and can be orientated in numerous positions to avoid interference with implement components.

Emblem is to be 2 to 6 feet above the ground measured from the bottom edge of the emblem.

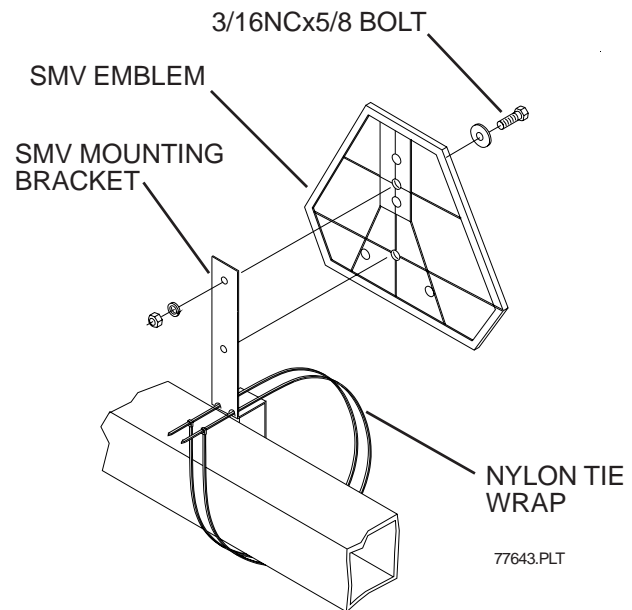

Keep safety decals clean. Replace any safety decals that are damaged, destroyed, missing, painted over or can no longer be read. Replacement safety decals are available through your dealer.

## SAFETY CHAINS

The purpose of the safety chain is to provide an auxiliary attaching system to retain the connection between towing and towed machine in the event of separation of the primary attaching system.

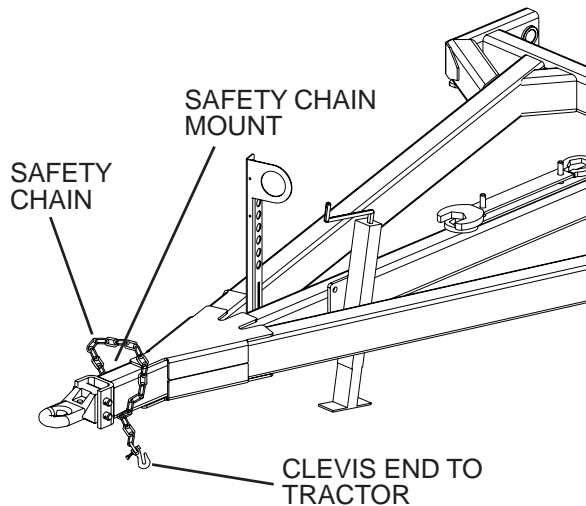

The safety chain should be hooked long enough to permit full turns. Unnecessary slack should be taken up.

The intermediate support is to be used if there is more than 6" of unsupported chain on either side of the primary attaching point.

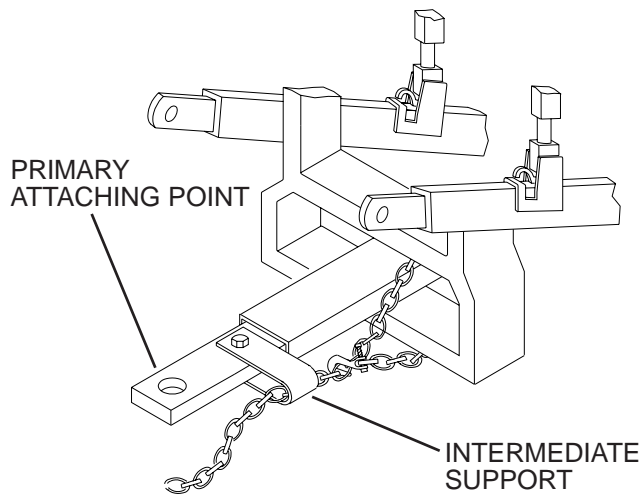

The intermediate support must not be mounted more than 6" from the primary attaching point (see illustration below.)

Safety decals appear at various locations on your machine. These decals are provided for your safety, your family's safety and your employee's safety. Replace any decal that becomes worn, damaged, painted over or difficult to rear.

Keep safety decals and signs clean and legible at all times.

Replace safety decals and signs that are missing or have become illegible.

Replaced parts that displayed a safety sign should also display the current sign.

Safety decals or signs are available from your Dealer Parts Department.

### How to install Safety Decals:

Be sure that the installation area is clean and dry.

Decide on the exact position before you remove the backing paper.

Remove the smallest portion of the split backing paper.

Align the decal over the specified area and carefully press the small portion with the exposed sticky backing in place.

Slowly peel back the remaining paper and carefully smooth the remaining portion of the decal in place.

Small air pockets can be pierced with a pin and smoothed out using the piece of decal backing paper.

### Serial Plate

To insure efficient and prompt service please furnish us with the model and serial number of your 800NT series disc in all correspondence or other contacts. The serial plate is located on the front face of the center frame.



# **SPECIFICATIONS**

## **STANDARD EQUIPMENT**

28" x5/16" (814/842) OR 30"x5/16" (816/862)  
smooth blades

11" Blade spacing (814/842) OR 13" Blade  
spacing (816/862)

Tapered leveling blades

1-15/16" Round gang shaft

Hitch Jack

(2) - 4.5"x12" Transport cylinders

(2) - 4"x12" Transport cylinders

(2) - 5"x44" Wing lift cylinders OR

(4) - 5"x36" Wing lift cylinders (30-38FT)

Hydraulic hose carrier

Transport channel lock

Hydraulic system with manifold hoses to the  
tractor.

Adjustable blade scrapers

(8) - 385/65R22.5 Tires and Rims

2.75" Spindles on center axles and wing axles

Constant level spring loaded leveling  
adjustment

4"x8"x3/8" Framework

4"x6"x3/8" Gang tubes

214 Series Relube gang bearings

Cast Iron hitch

Gang shaft wrench and U-bolt wrench

Tandem Axles on center frame and wings

## **OPTIONAL EQUIPMENT**

- Leveling Harrow Attachment
- Hydraulic Disc Leveler
- Notched Blades
- 10-bolt Mainframe Hubs (26ft and up)

## **GENERAL FEATURES**

Your 800NT Series disc is a flexible wing-type disk that features a constant-level, spring loaded leveling adjustment that keeps the disk at a level position at all soil depths and when in the transport position.

The front gangs are offset and overlapped to make a complete cut. The rear gangs are spaced to leave a level field. Wings are supported by wide-spaced flotation tires which allow maximum response to uneven ground. Wings will flex 5° up or down.

## **HYDRAULIC CYLINDERS**

The hydraulic components received with your disk were selected to deliver the most efficient and economical use. Any parts for replacement should be replaced with parts of the same type and size. Replace any hoses or fittings which develop leaks

Standard equipment for your disc includes all hydraulic cylinders, fittings, and hoses from the cylinders to the tractor. The main lift cylinders are provided with O-ring ports. The wing fold cylinders have O-ring ports. Hoses and fittings are provided that attach to these cylinders. The remaining fittings and hose ends are "JIC" fittings (**not pipe thread**) except the 1/2" male pipe fitting at the end of the hose leading to the tractor.

The lifting system uses (2) 4.5"x12" & (2) 4"x12" phasing type cylinder. The wing folding system uses either (2) 5" bore x 44" stroke cylinders, or (4) 5" bore x 36" stroke cylinders, depending on size.

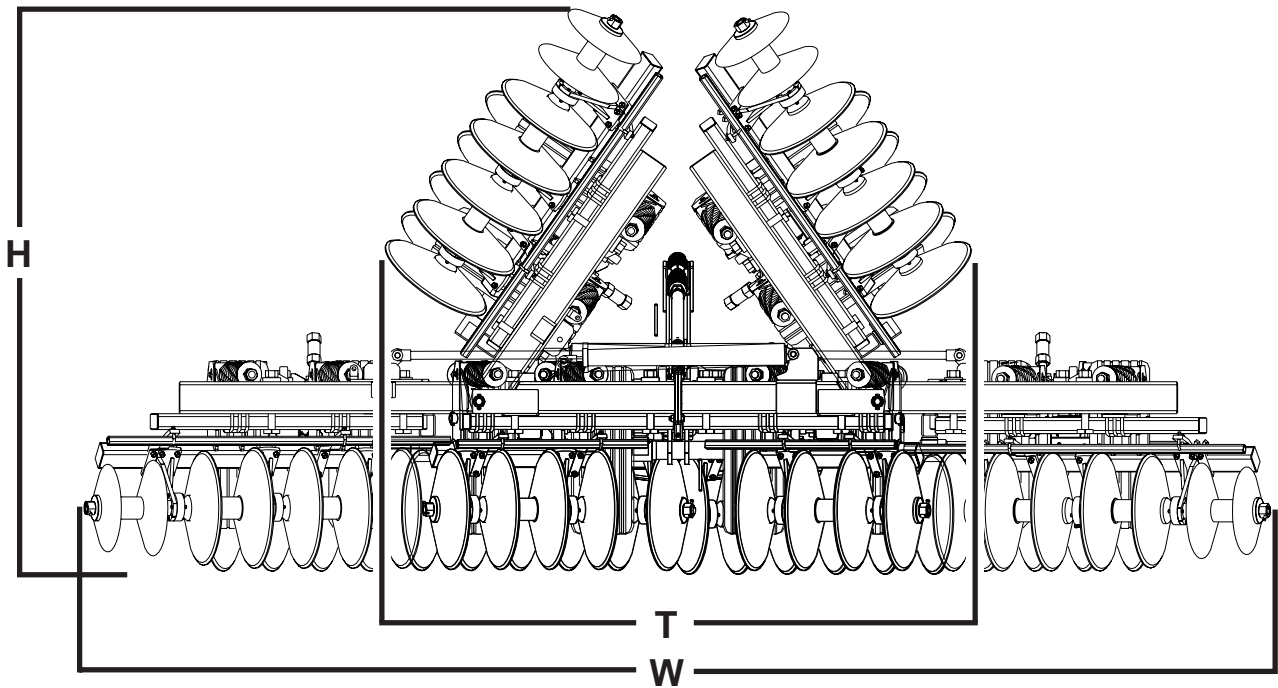

**Figure 1:**

Model No.	Width of Cut	Blade DIA.	No. of BRGS	No. of BLADES	Weight	Transport Height (H)	Transport Width (T)	Overall Width (W)
842NT-22	22'8"	28x5/16	22	50	26,000lbs	12'10"	12'6"	23'10"
842NT-26	25'5"	28x5/16	24	58	28,800 lbs	14'2"	13'6"	28'4"
842NT-30	28'11"	28x5/16	30	66	31,700 lbs	15'6"	15'0"	31'10"
862NT-22	21'6"	30x5/16	20	42	26,300 lbs	12'10"	12'6"	24'8"
862NT-26	26'8"	30x5/16	22	50	27,800lbs	14'2"	13'6"	28'6"
862NT-30	30'9"	30x5/16	26	58	30,500lbs	15'10"	14'8"	32'10"
816NT-22	21'6"	30x5/16	20	42	22,000lbs	12'10"	12'6"	24'8"
816NT-30	30'9"	30x5/16	26	58	26,200lbs	15'10"	14'8"	32'10"



# SAFETY DECALS PLACEMENT

The SMV (Slow Moving Vehicle) Emblem is a recommended attachment that should be added to the rear of the disc. When transporting the disc over public roads, the SMV Emblem must be used, for protection of tractor and motor vehicle operators.

SEE PAGE 62 FOR  
HAZARD LIGHTING  
ASSEMBLY

\* SEE PAGE 17  
FOR DECAL  
PART NUMBERS

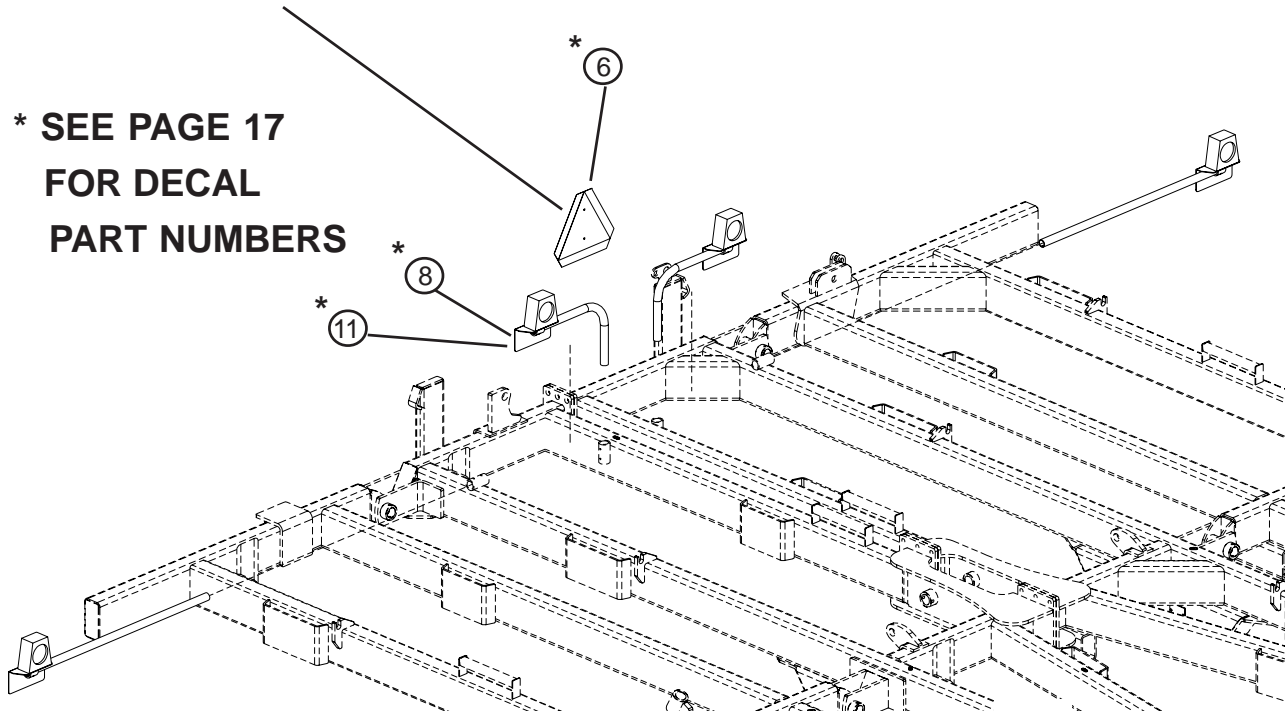

**NOTE:** Replace any safety decals that become worn or difficult to read; replace all safety decals when repainting.



**CAUTION:** When trailing the disc on public roads the SMV Emblem must be used, for protection of tractor and motor vehicle operators.



**CAUTION:** When transporting machinery over public roads, comply with your local and state laws regarding length, width, and lighting.

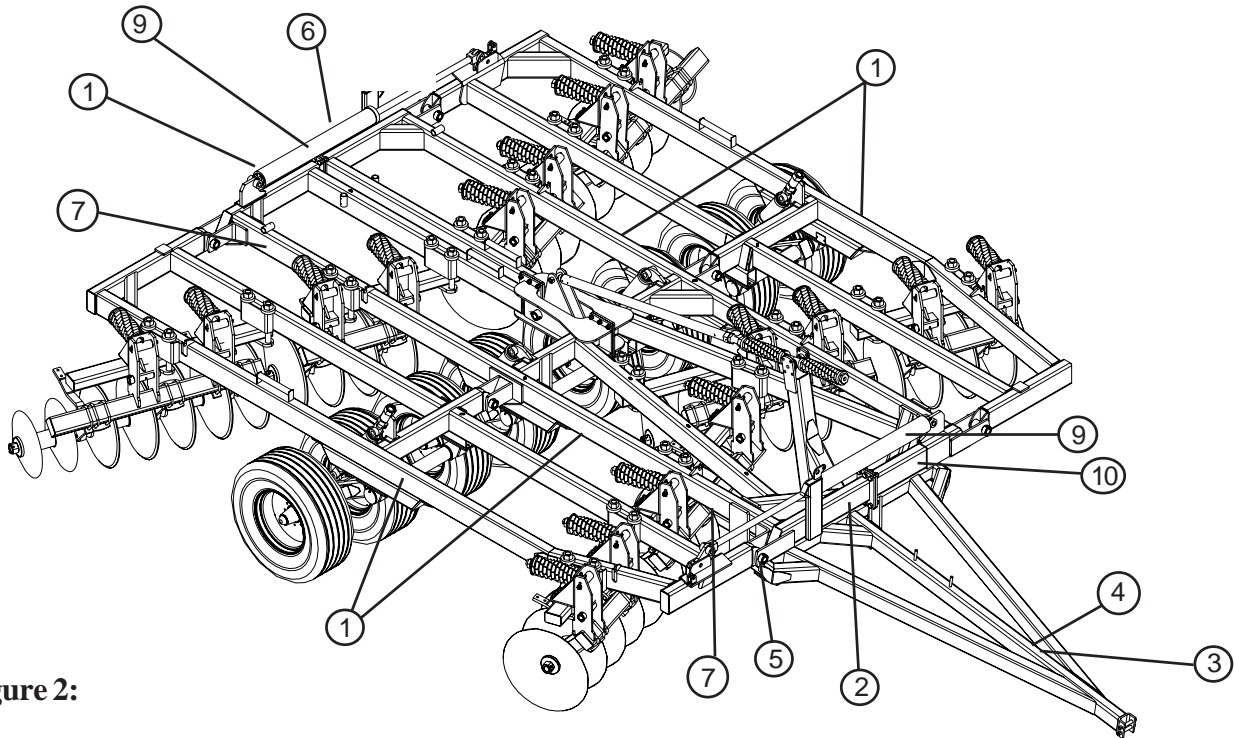
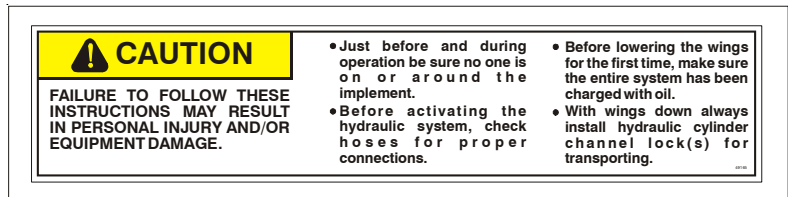

Figure 2:



862NT 842NT 816NT  
 2 - 243348                      243349                      243351  
 - Model Decal

1 - 243346 - Wishek Decal



3 - 49165 - Caution Decal



5 - 24011 - Lubrication Decal

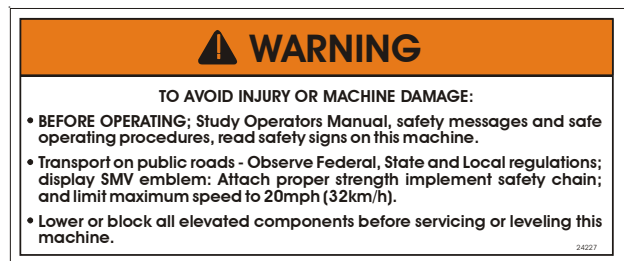

4 - 24227 - Warning Decal

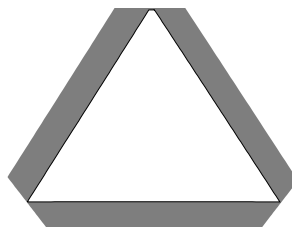

6 - 41345 - SMV Kit

7 - 22372 - Amber Reflector



8 - 22371 - Red Reflector



9 - 24218-Caution Decal

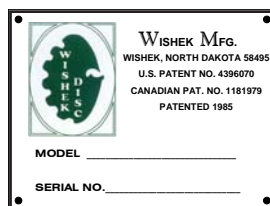

10 - Serial Number Plate Location



11 - 223118 - Fluorescent Orange Reflector

# GENERAL OPERATING INSTRUCTIONS



## WARNING

1. BEFORE OPERATING - STUDY OPERATORS MANUAL, SAFETY MESSAGES AND SAFE OPERATING PROCEDURES, READ SAFETY SIGNS ON THIS MACHINE.
2. TRANSPORT ON PUBLIC ROADS - OBSERVE FEDERAL, STATE AND LOCAL REGULATIONS; DISPLAY SMV EMBLEM; ATTACH PROPER STRENGTH IMPLEMENT SAFETY CHAIN; AND LIMIT MAXIMUM SPEED TO 20MPH (32 km/h)
3. LOWER OR BLOCK ALL ELEVATED COMPONENTS BEFORE SERVICING OR LEAVING THIS MACHINE.

For economical and efficient operating, the operator must be aware of all the adjustments which should be considered for the best results. The operator should know what adjustments must be made for different conditions.

## HITCHING INSTRUCTIONS

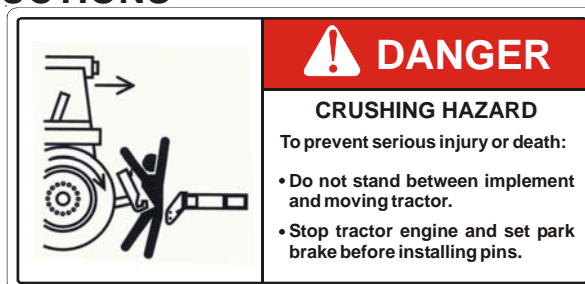

## JACK

The 800NT disc is equipped with a dropleg jack. (See Fig. 3)

To operate the jack, turn handle clockwise to extend and counter-clockwise to retract.

Refer to next page for jack shown in operating position.

Figure 3:

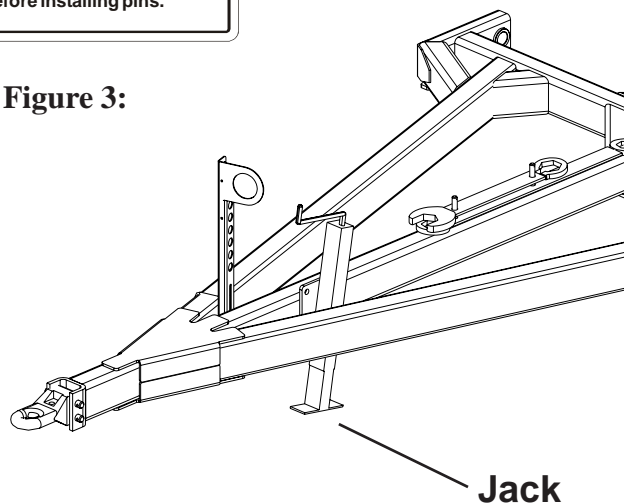

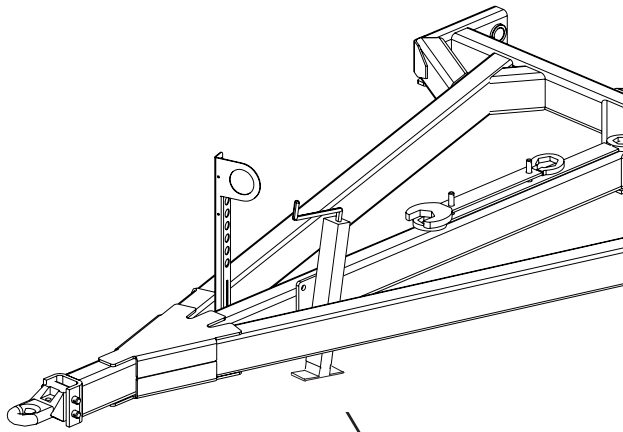

### Jack Transport Position

Figure 4:

The jack is shown here in the transport position.

(See Figure 4)



**CAUTION:** Before placing the jack into transport position, the hitch clevis should be secured to the drawbar to prevent the hitch from falling to the ground.

**IMPORTANT:** When working the disk, jack should be in transport position.

## HITCH PIN

The recommended hitch pin size is at least 2" in diameter and should be securely attached so that the pin can not inadvertently come out.



**CAUTION:** Park or block the disc so it will not roll when disconnected from the tractor drawbar.

## HYDRAULIC FITTINGS

All fittings for the hydraulic hoses are provided including Pioneer Quick Couplers to the tractor. The operator will need to furnish the hydraulic couplers, if Pioneer Quick Couplers provided aren't a match.



**CAUTION:** Do not connect or disconnect hydraulic components when there is pressure within the system. Hydraulic systems are highly pressurized. Escaping hydraulic oil, even an invisible pinhole leak, can penetrate body tissues and cause serious injury. Use a piece of wood or cardboard when looking for leaks. Never use the hands or other parts of the body. When reassembling, make absolutely certain that all connections are tight. If injured by hydraulic oil escaping under pressure, see a doctor immediately. Serious infection or reaction may occur if medical attention is not received at once.

# TOWING INSTRUCTIONS



**CAUTION:** Observe safe driving practices; comply with your local and state laws regarding length, width, and lighting. Be aware of low and narrow passages both in the field and on the road.

Figure 5:

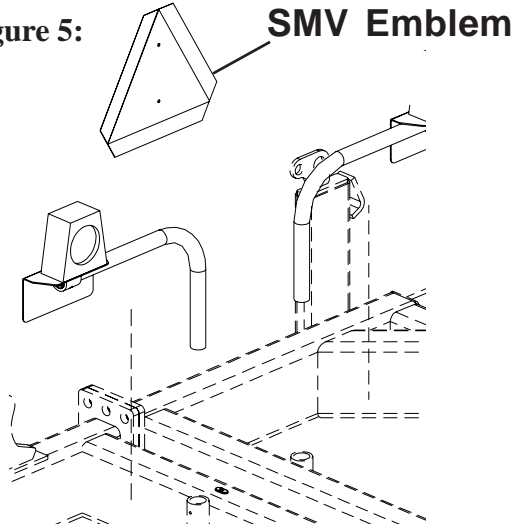

## SMV EMBLEM

When trailing the disc on public roads, the SMV emblem must be used, for protection of tractor and motor vehicle operators. (See Figure 5)

# TRANSPORT LOCKOUT

When transporting or working on the machine in the raised position, the channel lock must be used to prevent the machine from falling in case of a hydraulic component failure. The lockout is secured with a lynch pin. (See Figure 6)

Figure 6:

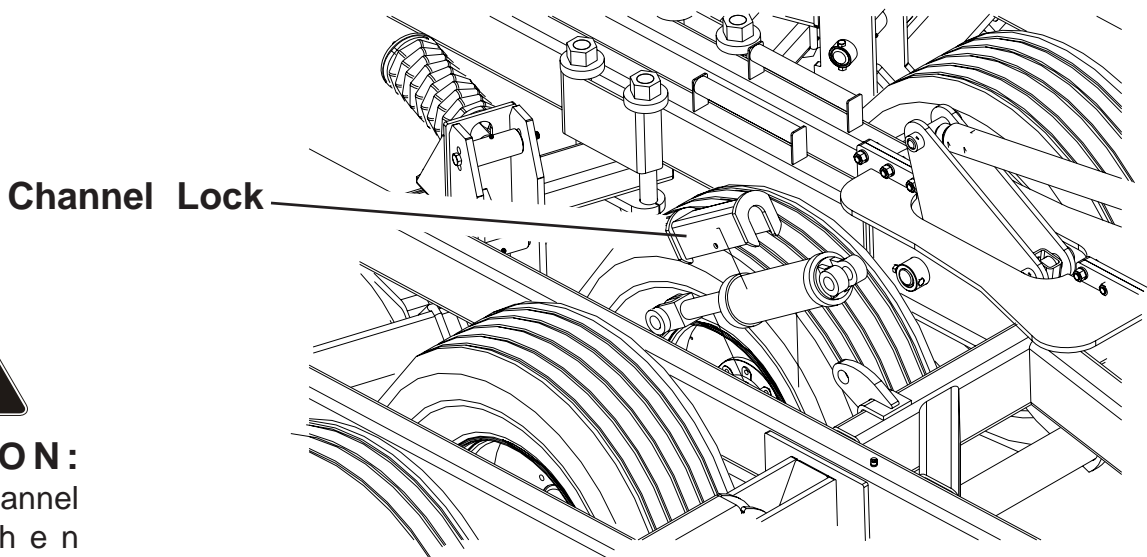

**CAUTION:**  
Secure channel  
Lock when  
transporting.

## WING LIFT CIRCUITRY

**WISHEK** Discs equipped with folding wings have hydraulic wing lift cylinders to fold the implement for road transport.

Fig. 7 shows a simple two (2) cylinder circuit used to fold Wishek Discs with a single pair of folding cylinders. Larger size disks use two pair of folding cylinders attached parallel.

When lowering the wings, hold the hydraulic control lever until cylinder wing linkages (pull-up dogs) are in mid-stroke. If possible, operate wing hydraulics in float position.

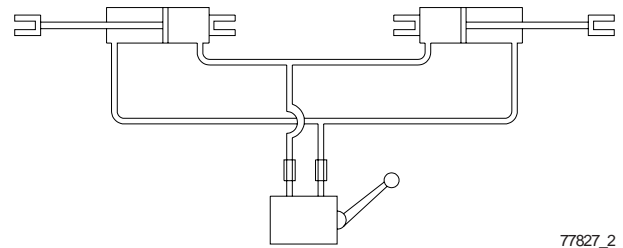

77827\_2

**Figure 7:**

Fold the main wings until they contact the wing rest.

# DEPTH CONTROL CIRCUITRY

This unit is equipped with a lift system that utilizes phasing cylinders. In a phasing system the cylinders are sized to operate in series and provide a level lift to the unit. The Wishek phasing system utilizes equal length cylinders, while varying the bore. On this unit the center frame cylinders have a 4.5" bore diameter with a 4" bore wing cylinder. See Fig. 8 .

The cylinders are connected in series with the rod end of the center frame cylinders connected to the base end of the wing cylinders.

To accomplish proper phasing, it is necessary to hold lever in raised position for a few seconds to purge air from system.

After oil has "rephased" the system, leave depth control in neutral position at least three seconds to allow the cylinders to settle far enough to close the rephase passages and completely rephase the system.

**Note: This system requires periodic raising of the unit and holding of the tractor valve to expel air or contaminants**

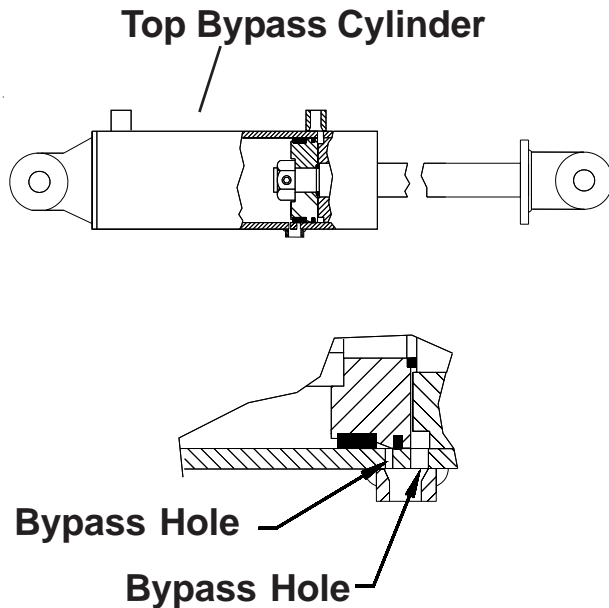

**Note: To phase or re-phase the system, the tractor control valve must be held in the raised position until the entire implement is raised and any air that may be in the lines has been expelled.**



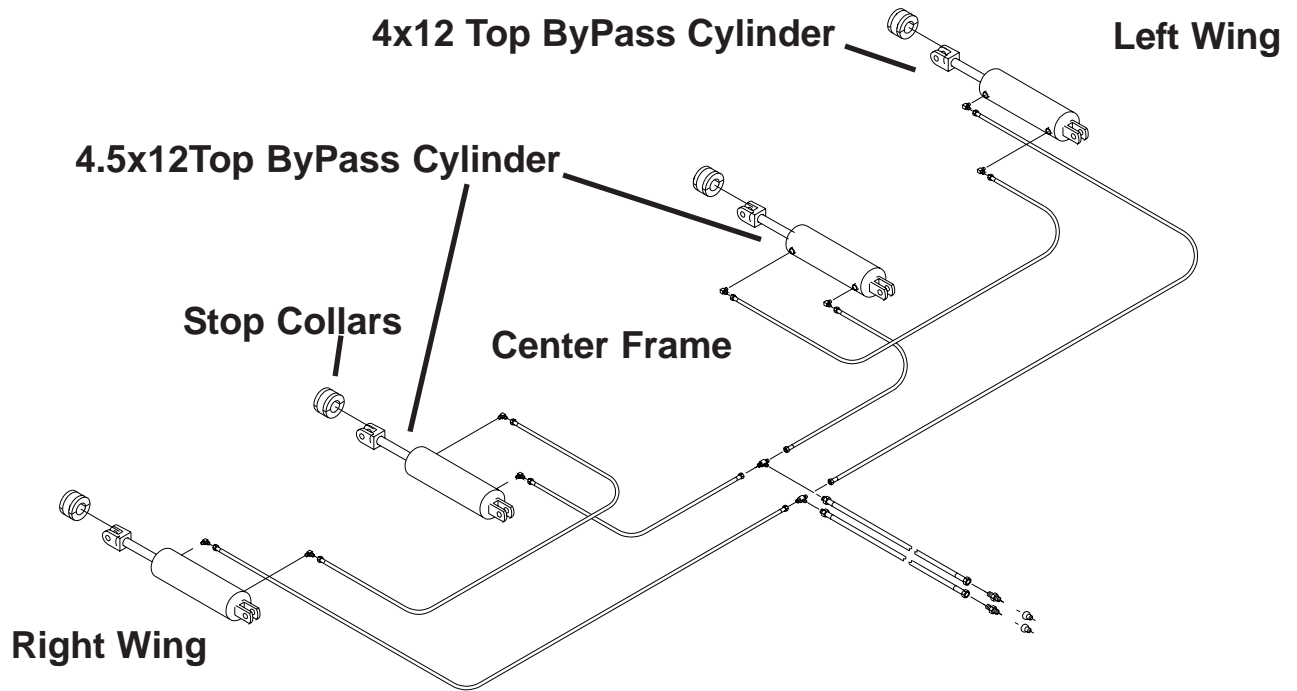

Figure 8:

## DEPTH SETTING

To ensure even field depth across width of unit, cylinder stops will need to be used on all lift cylinders.

If further leveling of the unit is required, you will need to adjust the wing cylinder lollipop to raise the wing. (See page 40)

# FRONT WING LOCKOUT

The front wing lockouts should be used whenever the wings are in a folded position.

To lock wings, place wing lock pin through ears of wing rest and the clevis on the wing (see figure 9) and place hair pin through pin. It is important that the hair pin be placed securely on hitch pin to prevent pin from falling out. When wing is unfolded the pin can be stored in its holder to prevent loss. The holder is located on the same ear as the locking location.

Figure 9:

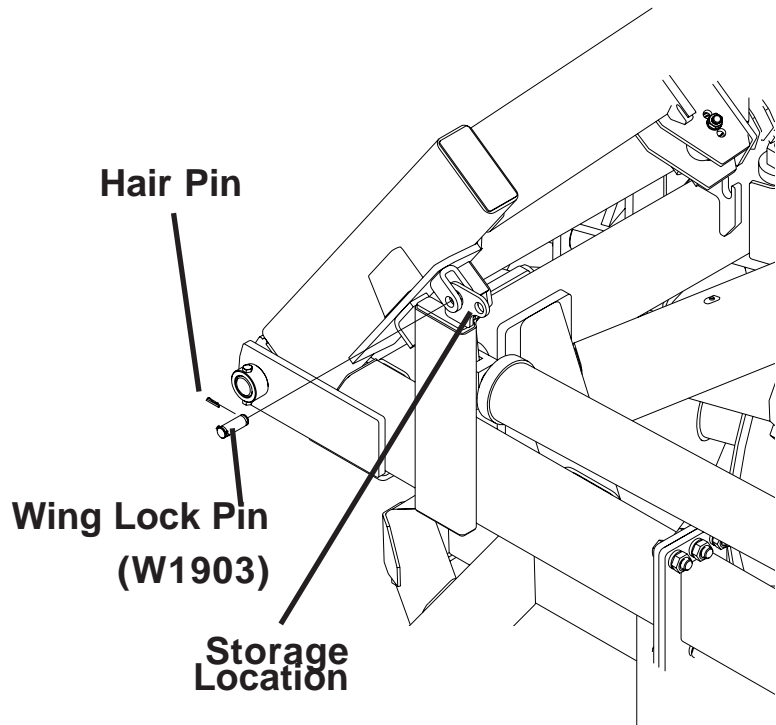

**CAUTION:** Do not stand or work under disc wings unless wing lock pins are installed. Accidental

operation of hydraulic lever or failure of any hydraulic components could cause disc wing to drop.

	<p><b>! DANGER</b></p> <p><b>STAND CLEAR AT ALL TIMES</b></p>	<ul style="list-style-type: none"><li>• Never walk or stand in the path of the wings.</li><li>• Completely lower wings before performing service or adjustments.</li><li>• Failure to do so will result in serious injury or death.</li></ul> <p><small>222800</small></p>
---	---	--

## ADJUSTMENT FOR LEVELING

Different depth settings for front and rear gangs can be used to achieve the desired results. This adjustment will vary depending on soil conditions. The tension on the cushion springs is preset at the factory to allow the disc to flex when going over dead furrows or other uneven land. To lock the leveling screw, use the jam nut. (See Figure 11)

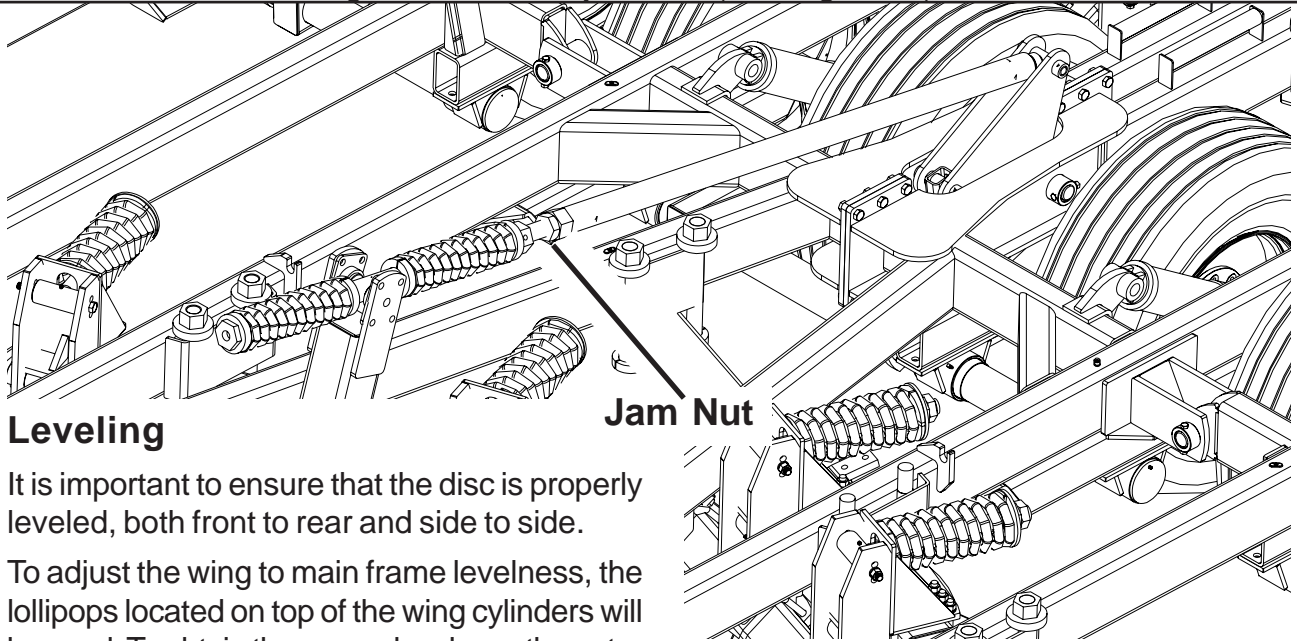

### Leveling

It is important to ensure that the disc is properly leveled, both front to rear and side to side.

To adjust the wing to main frame levelness, the lollipops located on top of the wing cylinders will be used. To obtain the proper levelness the outer most front blade on each wing should be about 1/2" above the center blades.

To adjust the front to back levelness of the disc, the leveling screw that attaches the hitch to the axle will need to be adjusted. For proper initial adjustment, the front gang should contact the ground slightly before the rear gang when lowering.

### SCRAPER ADJUSTMENT

The hardened steel scrapers provide a continuous cleaning action when properly adjusted. It is important that the clearance be checked daily under normal soil tilling conditions and more often in extremely trashy disking.

Each scraper may be adjusted by loosening the U-bolts and sliding the assembly along the scraper bar. (See Figure 12)

### SCRAPER GAP SETTINGS

(scraper to blade distance)

**Standard/Spool** - 1/8in

**Bearing Stand**- Concave: 1/8in, Convex: 3/4in

**Rotary** - Lower 2/3 of disc lightly contact blade

Figure 11:

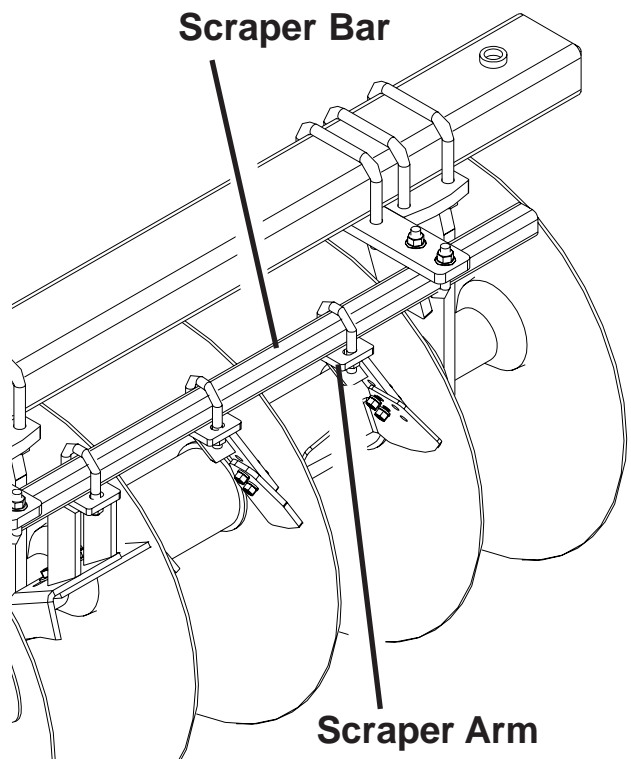

Figure 12:

## **FIELD SETTING**

Even if the unit has been leveled in the yard, it should never be assumed that the unit would operate level in the field without checking or adjustments. Changing field conditions, loading of the blade and attachments will impact the functional level and working in the field.

Move to the field and stop the unit in a level area. Unfold the wings; making certain that there is adequate room, with no person or obstruction in the wing fold area. Remove and store the wing lock pins. Activate the main lift hydraulics, and remove the transport channel locks from the main lift cylinders.

Make a visual inspection of the unit to ensure that all hardware is properly tightened, hoses are clear and that the unit is ready for field operation.

Stop collars should have been removed for yard adjustment and all screw collars should be turned to the clevis end. Cycle the main lift hydraulics a few times to purge any air from the system.

Once the main frame has been leveled by adjusting the leveling screw, move into the field at operational depth and stop the unit. Measure the frame height of the wing at the rear of the wing and compare to the frame height at the main frame. Adjust the wing eye bolt screw to level the wing to the main frame. Repeat the same procedure for the opposite wing.

### **OPERATING SPEED**

Best results will be achieved when operating speed of 4.5 to 5.5 miles per hour is maintained. Speed may need to be varied to achieve proper finish of field. High speed will increase the chance of damage to the machine, when striking foreign objects such as rocks or stumps.

Lift machine out of the ground when making turns. This avoids serious ridging and high stresses on the machine.

# **MAINTENANCE/LUBRICATION**

**REMEMBER:** Accidents don't always happen to the other guy so take great care when performing maintenance.

Periodic preventative maintenance such as tightening bolts, replacing worn pins, and proper lubrication will do much to extend the useful trouble-free of the Wishek Disc and provide the owner with the maximum operational performance.

After two hours and again after the first eight hours of operation the following checks and adjustments should be made.

- 1 Check and tighten, if necessary, all gang shaft nuts. Tighten to at least 2000ft pounds, then to next closest stop bolt. Keyway on gang shaft. NEVER loosen gang shaft nut to set bolt in keyway.
- 2 Tighten all bolts. Especially the bearing stand bolts. Tighten all bolts to torques specified. When bolts are replaced, be sure they are replaced with bolts of equal strength. See bolt head markings on bolt chart. (See Chart on Page 6)
- 3 Check wheel bearings and tighten if necessary. Check and tighten wheel lug bolts.
- 4 Check all pins to see they are securely fastened.
- 5 Check and adjust scrapers. Scrapers should be adjusted according to the scraper adjustment section of this book.
- 6 Lubricate various components that require lubrication. Use Wil-rich 460ep tillage lubricant. (See Pages 28-29)
- 7 Check all hydraulic components and connections for leaks. Replace any hoses or fittings that develop leaks.

Use the above list as a general guide for later checks and adjustments.



**CAUTION:** Never clean, adjust, or lubricate a disc that is in motion.

## GANG BOLT WRENCH

The wrenches, stored on the tongue frame, are useful tools for tightening or loosening gang shaft nuts and gang caster clamps.

**NOTE:** When storing gang wrench on frame use clip provided to hold gang wrenches to the stud on the frame.

## LUBRICATION

For economical and efficient operation, the proper lubrication of the disc is important. The following will detail the parts needing lubrication and the various conditions which determines the time span.

There are eight hubs and spindles that require seasonal lubrication.

The leveling screw has four places which should be lubricated. The top trunion has two and the leveling screw tube has one at the top and one at the bottom. These should be lubricated daily or as necessary. The threads on the leveling screw should be coated with oil occasionally to prevent rust and for a smoother operation.

Figure 15:

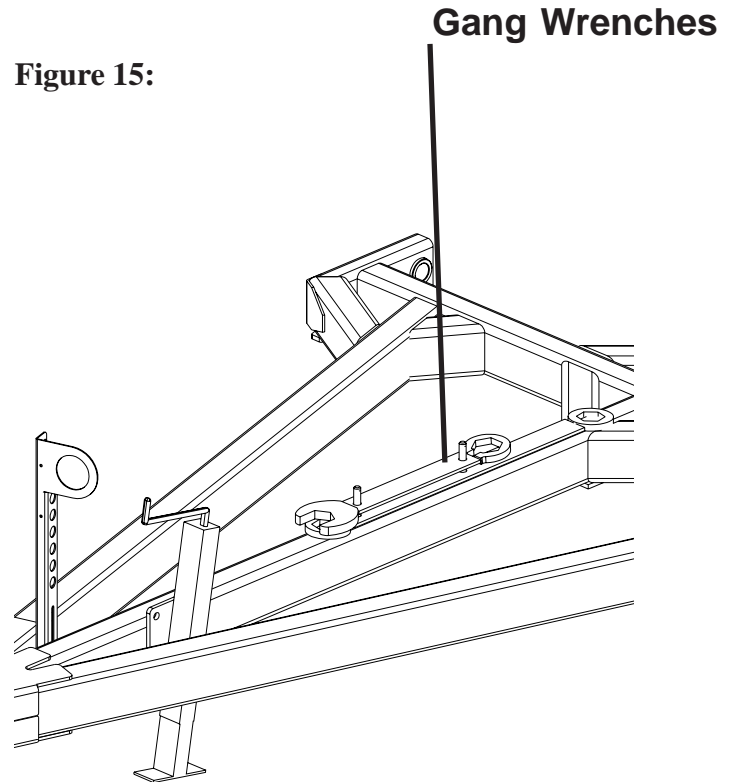

The Bell crank (center triangle) connects the leveling screw to the running gear. There are grease fittings located on the leveling pivot to allow the pivot pins to be greased. These should be lubricated daily during regular use.

All grease fittings excluding gang bearings should be greased daily and at start and end of each season for smooth operation.

**NOTE:** Be sure grease fittings are free of dust and paint before using grease gun. Replace any damaged or missing fittings.

## **GANG BEARINGS**

On the Wishek Disc, the gangs are supported by 214 re-lube gang ball bearings fitted with lubrication fittings. (See Figure 16)

The proper lubrication interval is 6-8 pumps of a handpump grease gun every 80 hours of operation.

There are no bearing adjustments to be made other than to make sure the brackets are firmly fastened.

They should also be lubricated at the start of each season and especially at the end of the season to protect against corrosion during storage.

**Only use a hand grease gun.** Wipe dirt from all grease fittings before lubricating. If a grease fitting is missing, replace it immediately.

### **IMPORTANT**

**LUBRICATE GANG BEARINGS  
USING HAND GREASE GUN ONLY  
6-8 PUMPS EVERY 80 HOURS**

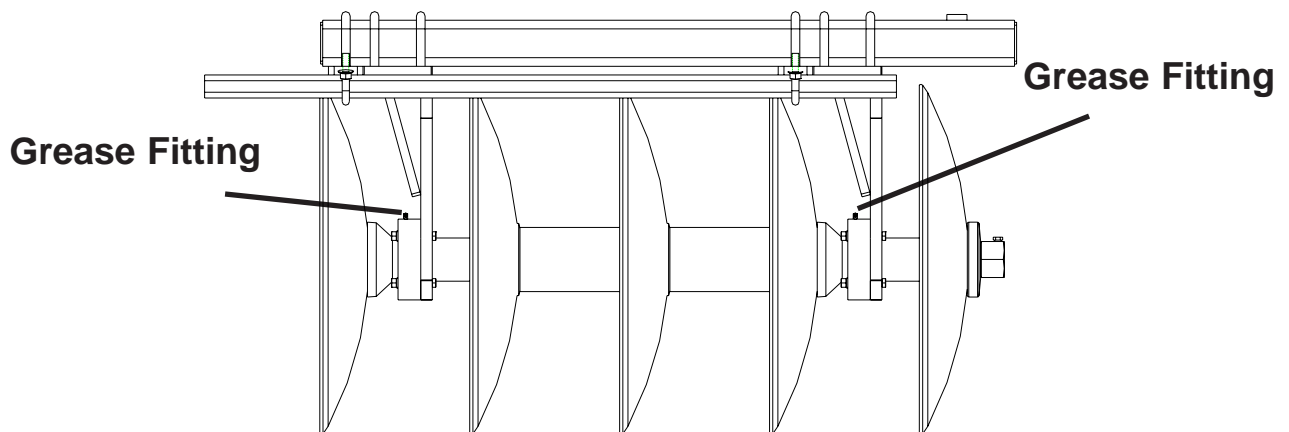

**Figure 16:**



## WHEEL BEARING - 8 BOLT

It is important that wheel bearings be repacked with grease and adjusted annually. Under hard working conditions, wheel bearings should be inspected more frequently - with occasional checks for excessive end play.

Care must be used in dismantling wheel bearing assembly. First remove the dust cap by prying around the edges. Remove the cotter pin, slotted nut, and flat washer. Carefully remove the hub and bearings from the spindle. Inspect all parts for wear or damage and replace with new parts if necessary.

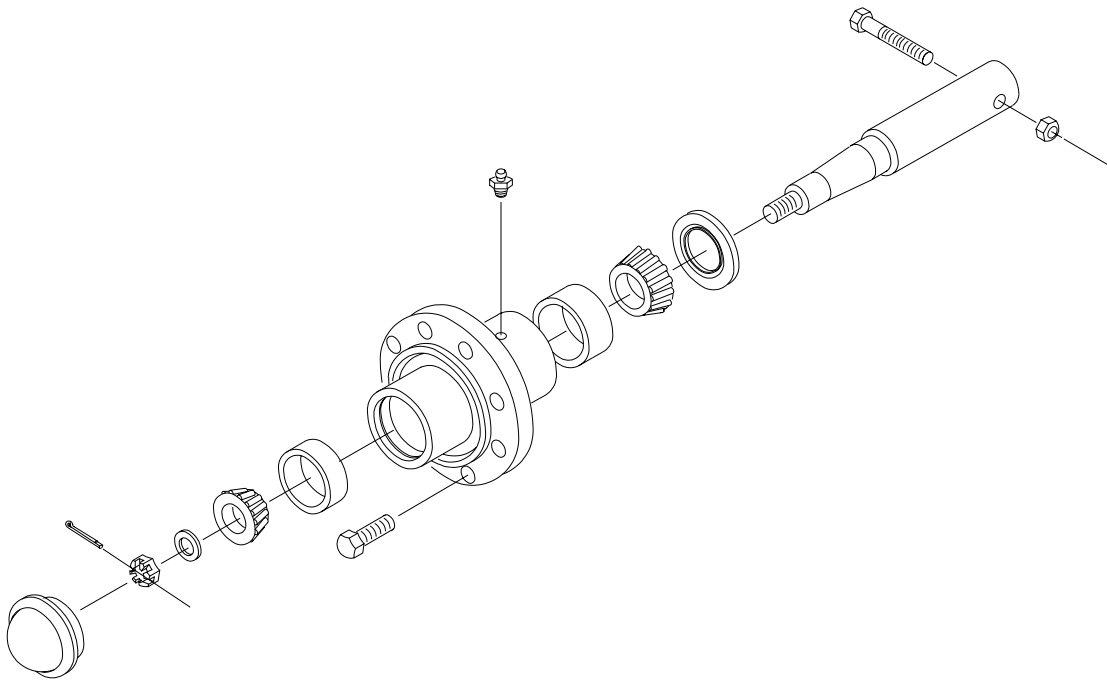

When reassembling the hub, repack both bearing cones with grease and fill the hub cavity 1/3 full. Place inner bearing assemblies into the hub, and then press grease seal into hub and carefully reinstall the hub on the spindle. When placing hub on spindle be careful not to damage the lip of the grease seal. Install outer bearing assembly into the hub and place flat washer and slotted nut. Then tighten the slotted nut to seal the bearings until the hub lightly binds as you rotate hub by hand. Back off the slotted nut to the next slot and place a new cotter pin in. Use a 3/16"x1-1/2" long cotter pin. Replace dust cap.

## **WHEEL BEARING - 10 BOLT**

It is important that wheel bearings be repacked with grease and adjusted annually. Under hard working conditions, wheel bearings should be inspected more frequently - with occasional checks for excessive end play.

Care must be used in dismantling wheel bearing assembly. Remove dust cap by removing bolts attaching it to housing. Remove the cotter pin, slotted nut, and flat washer. Carefully remove the hub and bearings from the spindle. Inspect all parts for wear or damage and replace with new parts if necessary.

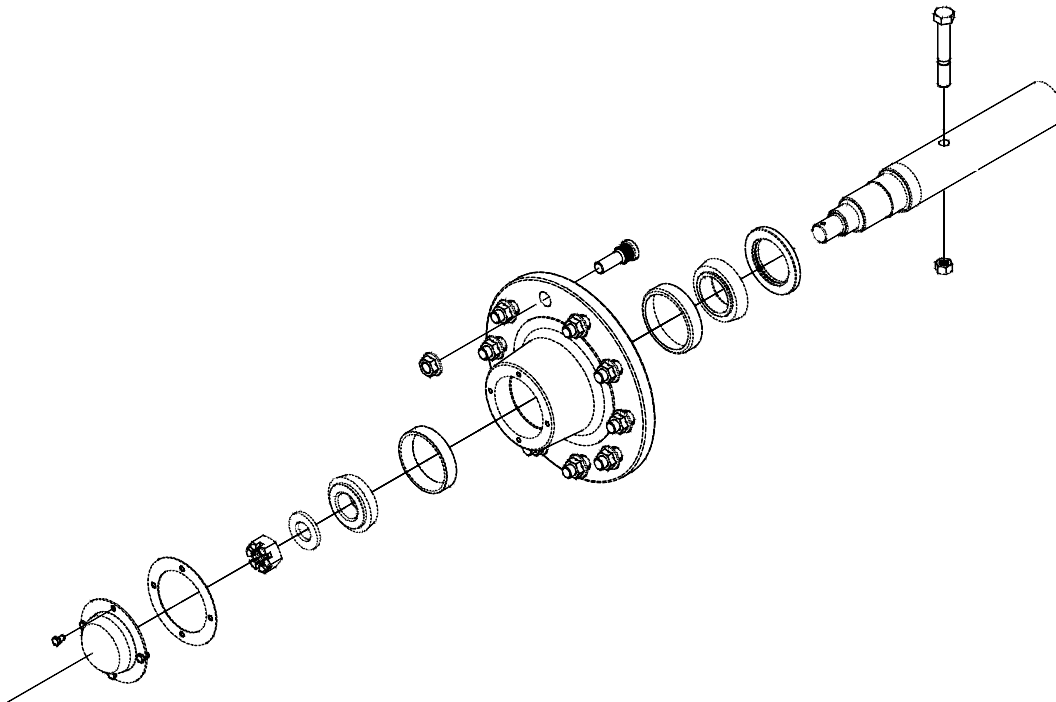

When reassembling the hub, repack both bearing cones with grease and fill the hub cavity 1/3 full. Place inner bearing assemblies into the hub, and then press grease seal into hub and carefully reinstall the hub on the spindle. When placing hub on spindle be careful not to damage the lip of the grease seal. Install outer bearing assembly into the hub and place flat washer and slotted nut. Then tighten the slotted nut to seal the bearings until the hub lightly binds as you rotate hub by hand. Back off the slotted nut to the next slot and place a new cotter pin in. Use a 1/4"x2-1/2" long cotter pin. Replace dust cap.

## **STORAGE**

Proper storage will add to the life of your disc and assure its being in good condition for the next season. The following procedure is recommended.

Clean off all foreign matter, and thoroughly lubricate disc.

Repaint the disc where the original paint has worn off.

Coat the disc blades and hydraulic cylinder rods with a good rust preventative. Tighten loose bolts and replace any damaged or missing parts

Carefully rotate each gang and check for worn or damaged blades, bent gang shafts, worn scrapers, damaged bearings and other parts which may need replacing.

Whenever disc blades or bearings are replaced, the gang shaft nuts must be torqued to a minimum of 2200 foot pounds. The nut should then be tightened to the NEXT set screw location.

Store in a dry place, with the gangs resting on boards to protect the disc blades and remove weight from the tires. Keep direct sunlight off the tires.

Store with wings down and transport locks engaged.



**CAUTION:** When working on disc, care should be exercised in handling or tightening bolts near disc blades to avoid injury.

## **DISC BLADES MAINTENANCE**

Do **NOT** run machine with loose disc blades. Keep gang bolts tight! Tighten to 2200 foot pounds. Use the gang bolt wrench provided with the machine with a “cheater bar”.

Rust and corrosion are the chief enemies of the disc. Spending a little time and effort protecting the disc blades will reward you with longer service, easier operation, and higher resale value. Dirt and trash will hold moisture, causing rust. Apply a good rust preventative to all land polished surfaces.

If the disc blades, bearings and spools must be replaced on the gang shaft, be sure to keep them in order when removing them so they can be replaced properly. The illustrations on page 51-59 will show the proper locations of the disc blades and bearings on the gang shaft. Remember the disc blades on the front gangs must be assembled to throw the soil out. The disc blades on the rear gangs are assembled to throw the soil in. Be careful to place each gang assembly in the same location on the frame from which it was removed.

# **TROUBLE SHOOTING**

<b><u>PROBLEM</u></b>	<b><u>POSSIBLE CAUSES</u></b>	<b><u>POSSIBLE REMEDY</u></b>
<b>Leaving center ridge.</b>	Excessive speed Rear Gangs cutting too deep and throwing excess dirt to the center Improper gang spacing	Reduce speed Use leveling adjustment reduce rear gang penetration Adjust spacing of gangs at center of machine
<b>Leaving center valley</b>	Discing too slowly Rear gang cutting too shallow Improper gang spacing	Increase speed Use leveling adjustment to increase rear gang penetration Adjust spacing of gangs at center of machine
<b>Gang plugging</b>	Extremely wet field Scraper adjusted improperly or severely worn	Allow to dry if possible or disc shallow once to aid drying time Adjust, service and/or replace scrapers as required
<b>Outside ridging</b>	Wings too deep Front gang too deep and the outside blades digging out more than the rear gangs can bring back Excess speed will also cause outside ridging (throwing dirt out further than the rear gang)	Adjust lollypop connector on wing axles to raise wing Use leveling adjustment to reduce front gang penetration Slow down tractor speed
<b>Cylinder stalling</b>	Hydraulic reservoir low Faulty plumbing Improper connections to tractor Channel lock installed	Add hydraulic oil to reservoir - see tractor manual for type and amount Check the routing of the hydraulic hoses - be sure there is no cross up in the lines Make sure circuits are not crossed at tractor Remove and store channel lock

# ASSEMBLY INSTRUCTION

It is very important that a new disc be properly assembled, adjusted, and lubricated before use. Follow the illustrations on these pages for proper assembly. Remove paint from grease fittings and replace any that are damaged or missing.

## BOLT INFORMATION

To insure alignment of assemblies, insert all bolts, leaving the nuts loose until completion of assembly. Use lockwashers or flat washers where called for. Spread all cotter pins.

All bolts should be tightened to the torques recommended in the table below. When bolts are replaced, be sure they are replaced with bolts of equal strength. See bolt head markings in table below.

**NOTE:** When hardware is plated, reduce torque values by 25%.

	GRADE 2			GRADE 5		GRADE 8	
TORQUE IN FOOT POUNDS							
BOLT DIA	3/8	1/2	5/8	3/4	7/8	1	
HEX HEAD	9/16	3/4	15/16	1-1/8	1-5/16	1-1/2	
UNC GR2	18	45	89	160	252	320	
UNC GR5	30	68	140	240	360	544	
UNC GR8	40	100	196	340	528	792	
UNF GR2	21	51	102	178	272	368	
UNF GR5	32	70	168	264	392	572	
UNF GR8	48	112	216	368	792	840	

TORQUE.EPS

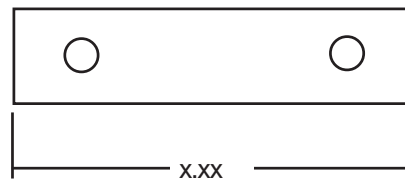
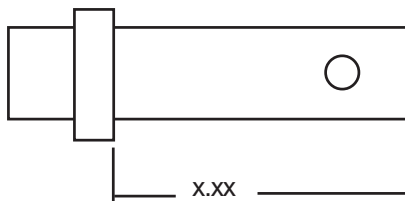

## PINS

Pins are dimensioned to the lengths shown above.

Some pins are prelocated in the holes in which they are to be used.

## Step 1 - Center Frame Assembly

Assemble right and left center frames together with 1"x3" grade #5 bolts, lockwashers and nuts on the front and rear plates. The two center plates receive 3/4"x2-1/2" grade #8 bolts, lockwashers and nuts. Place frame on sturdy stands at least 30" high. Position a stand under each corner.

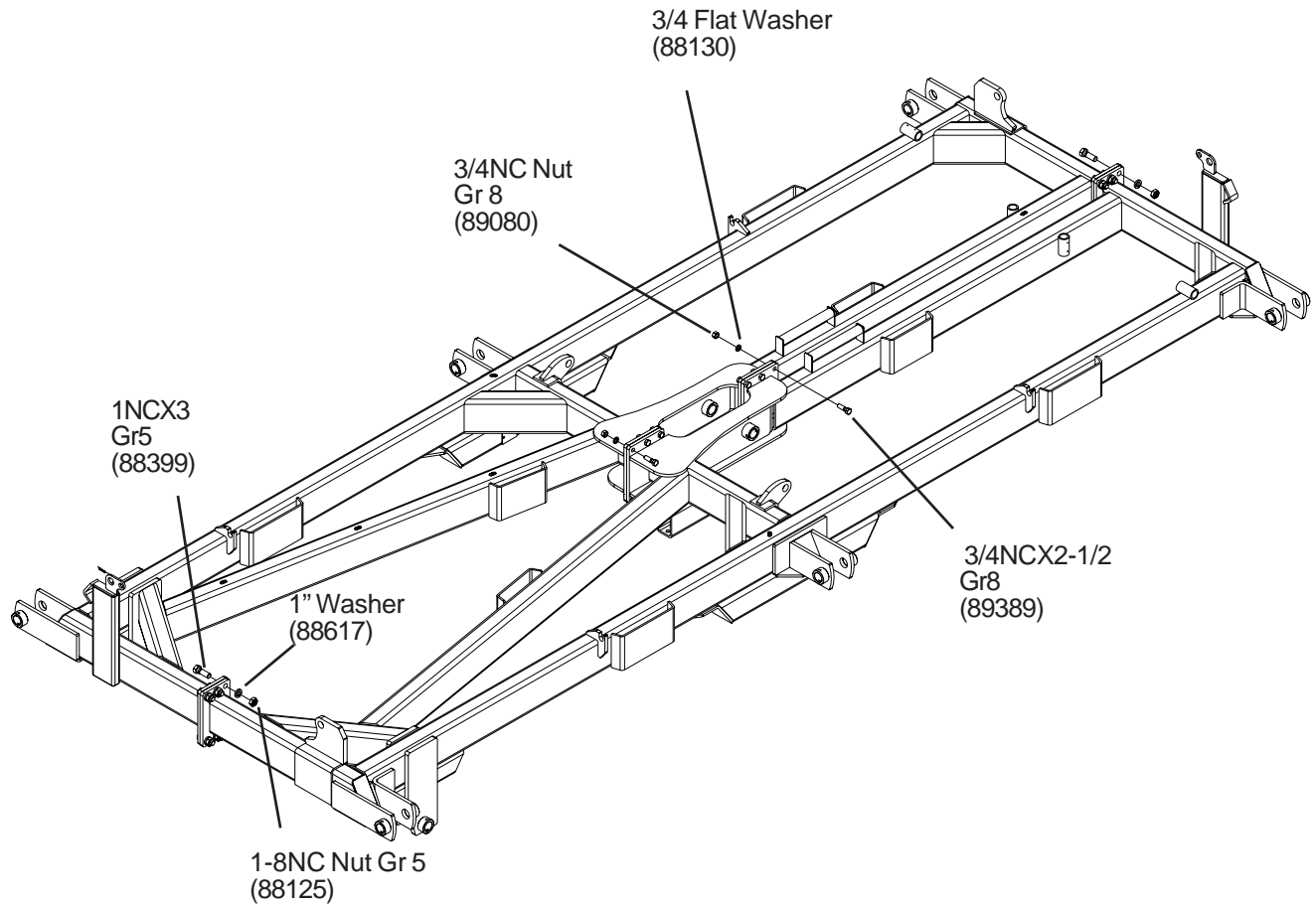

## Step 2 - Center Frame Assembly

Attach axle assembly to frame and attach wheel to hubs. Bolt the wheels to the hubs and tighten wheel bolts evenly to assure proper alignment of wheels. Be certain to position wheel with valve stem away from the spindle.

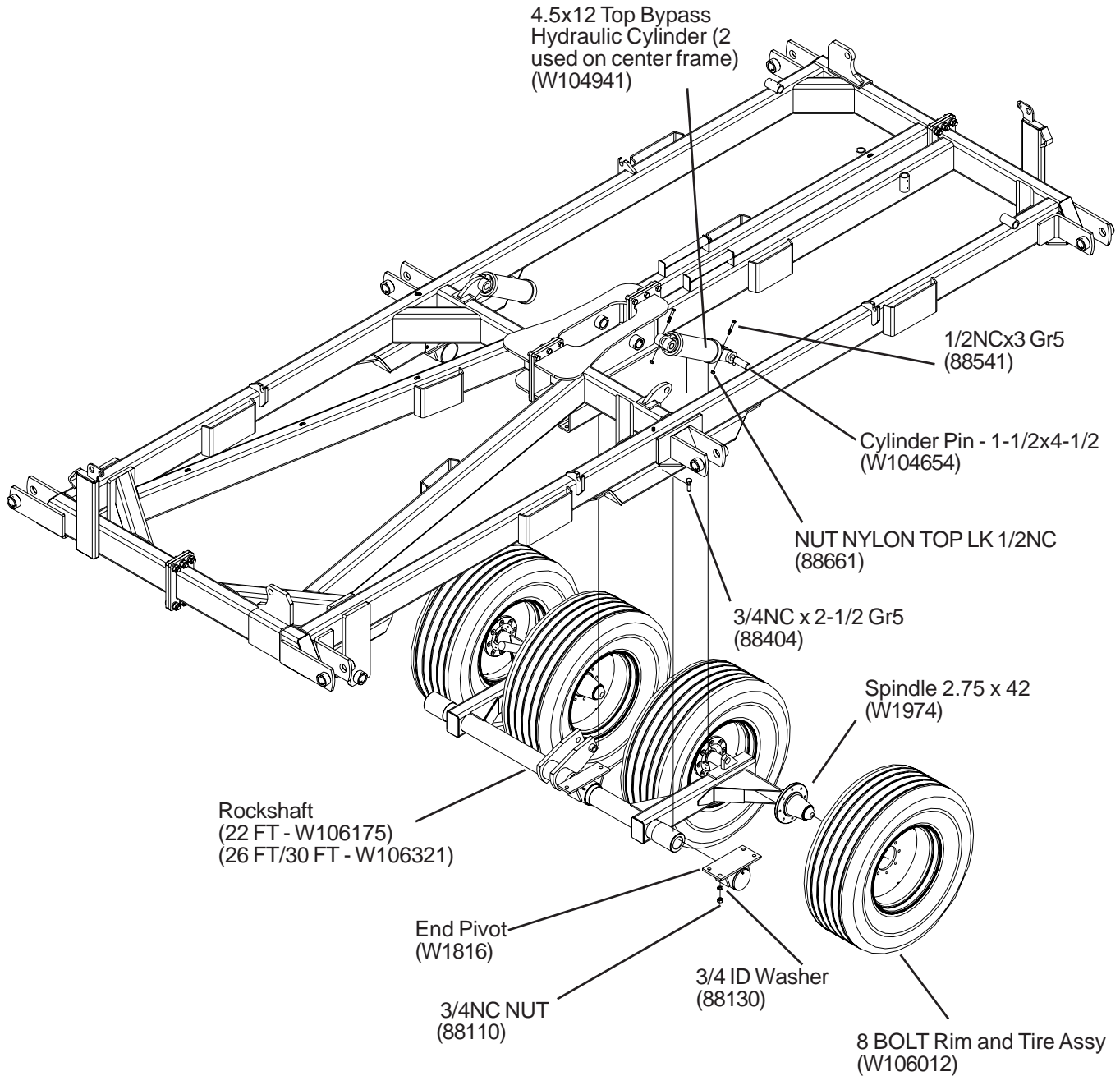



### Step 3 - Hitch Assembly

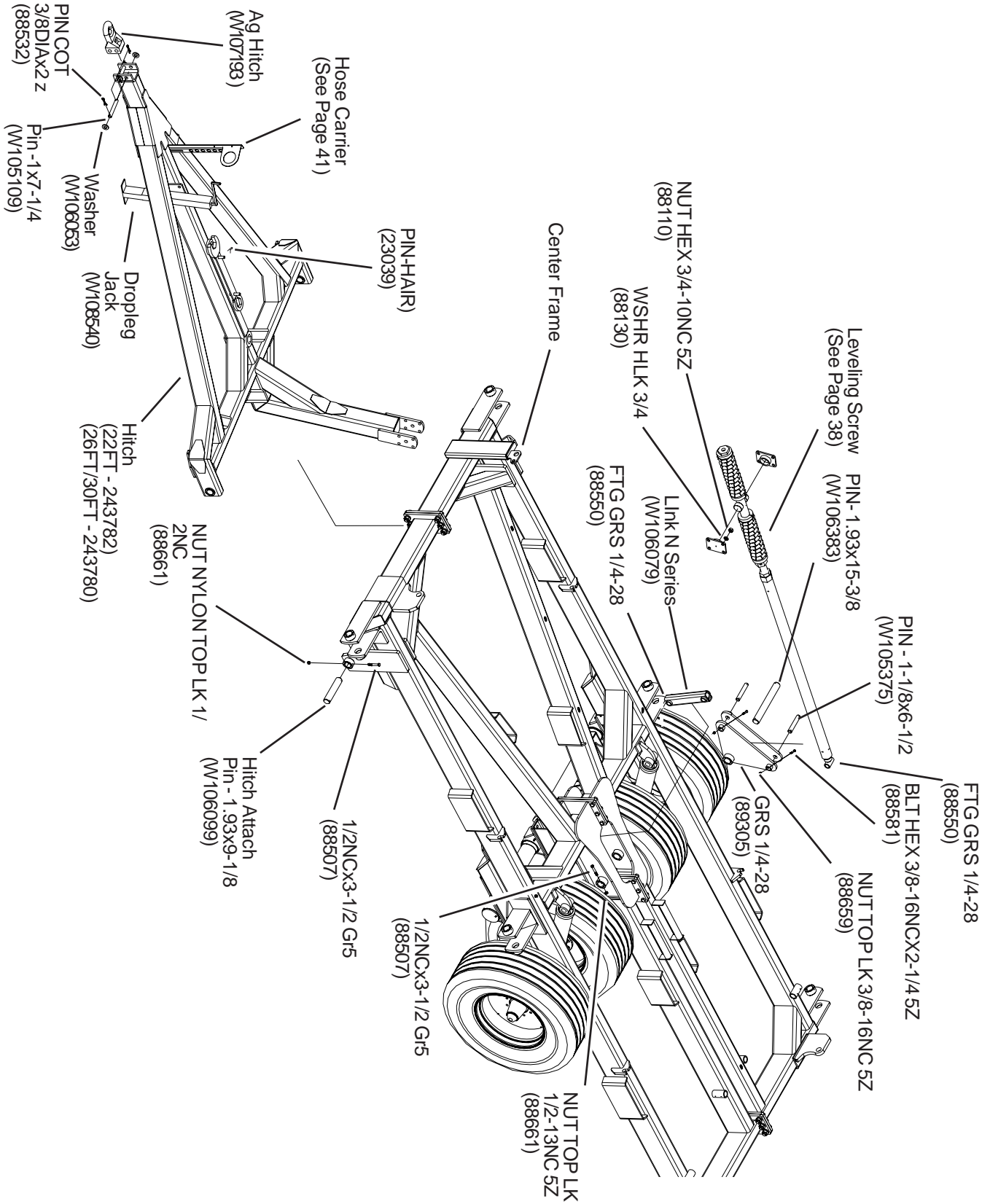

## Step 4 - Levelling Screw Assembly

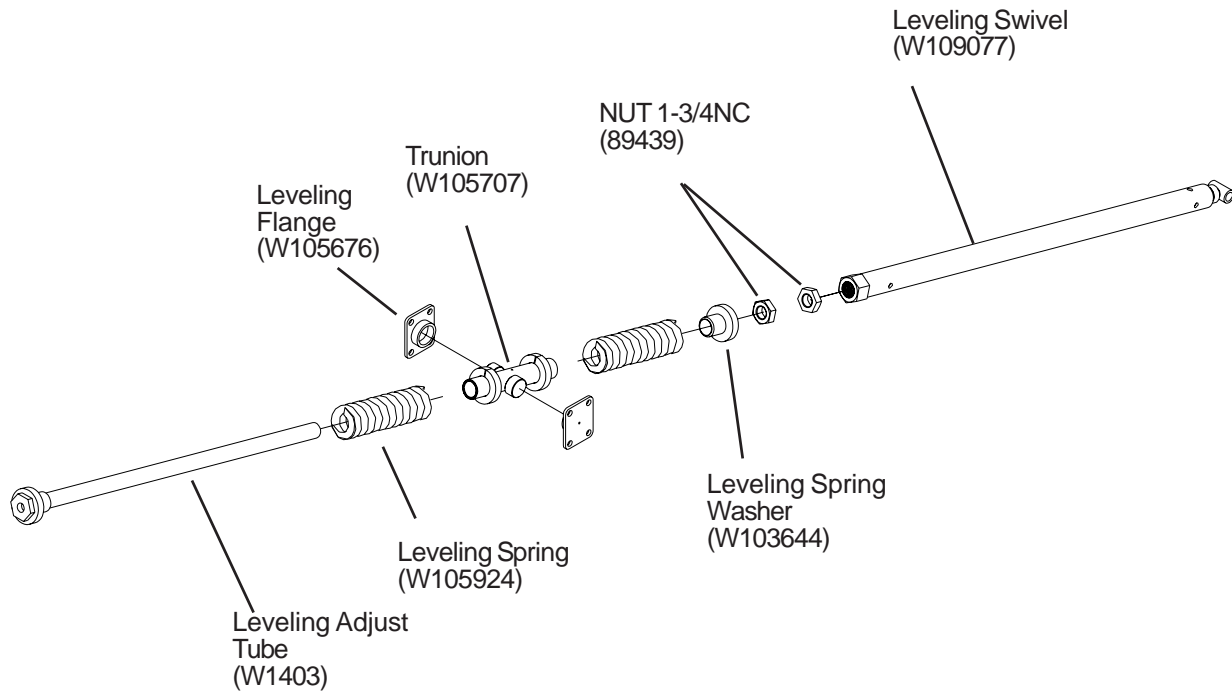

### Hydraulic Adjustment Option

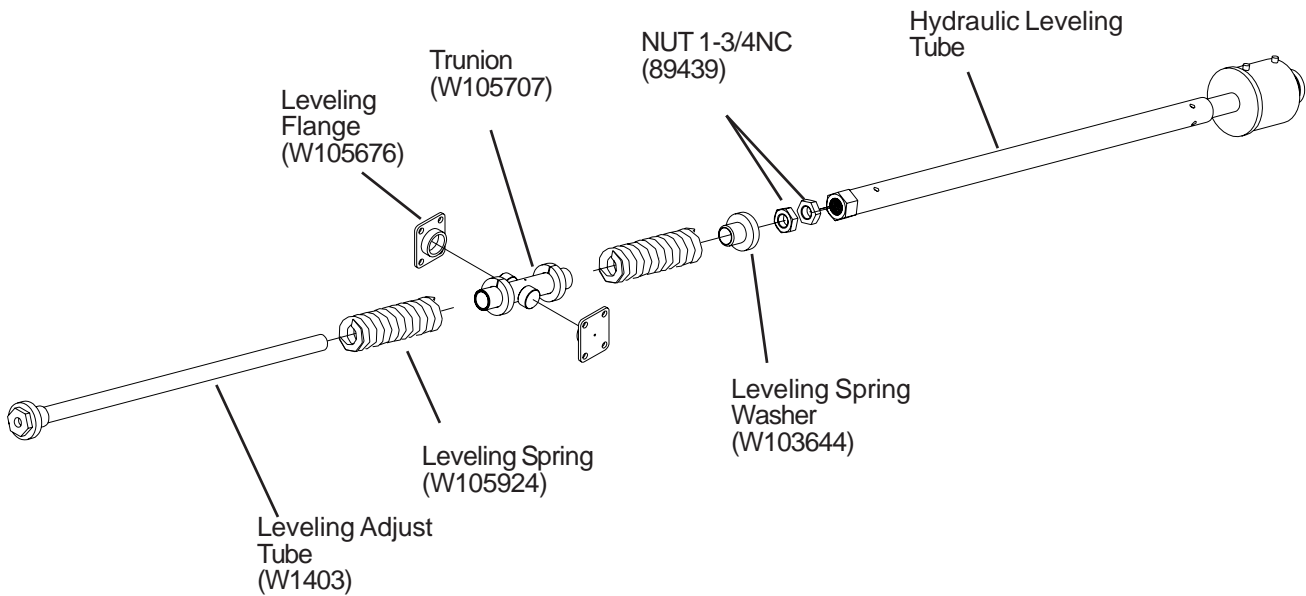

## Step 5 - Utility Pole Assembly

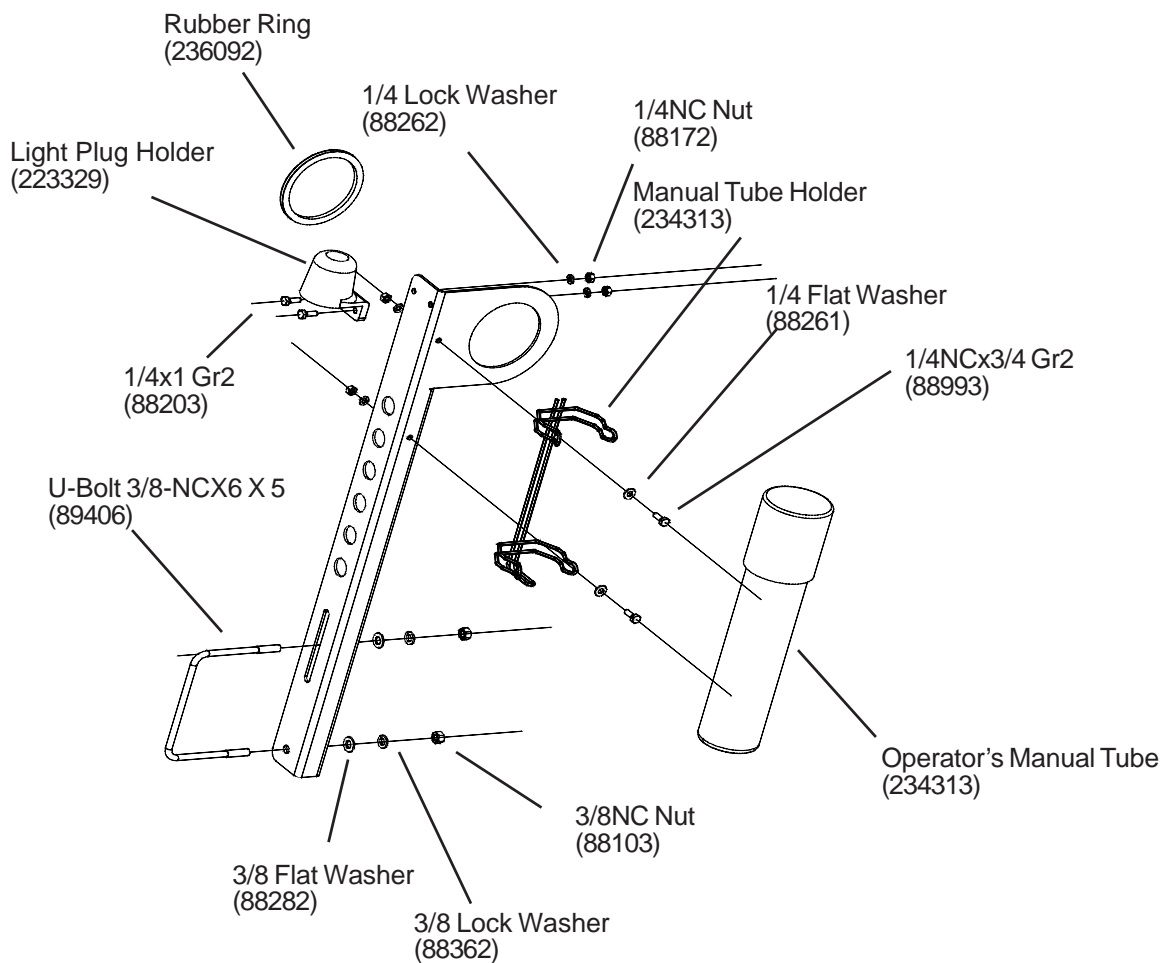

### Note:

Place the Utility Pole as close to the hitch point as possible without interfering with the tractor or implement.

The rubber edging is to be placed around the inside of the large loop to protect the hoses from scuffing.

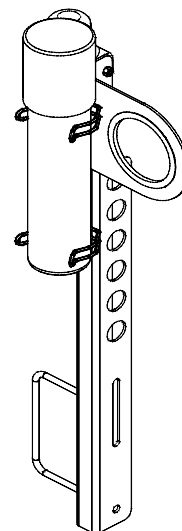

## Step 6 - Wing Frame Assembly (22FT & 26FT)

Mount wing frames to center frame.

**NOTE:** Following illustration shows left wing axle installation. Right wing axle is attached in the same manner.

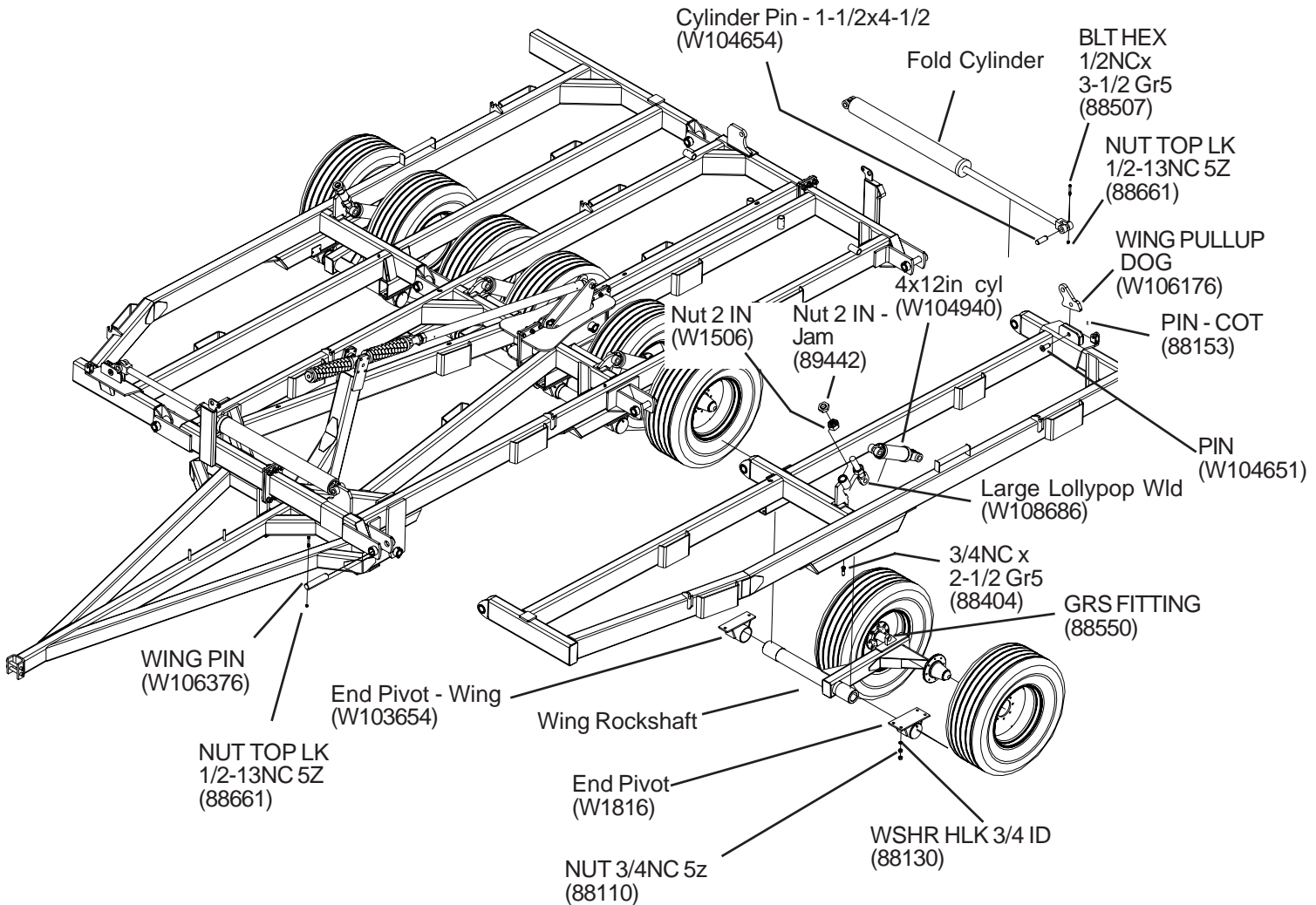

Left Wing Frame - Shown

	<p><b>! DANGER</b></p> <p><b>STAND CLEAR AT ALL TIMES</b></p>	<ul style="list-style-type: none"> <li>• Never walk or stand in the path of the wings.</li> <li>• Completely lower wings before performing service or adjustments.</li> <li>• Failure to do so will result in serious injury or death.</li> </ul>
--	---	---

222800

## Step 6 - Wing Frame Assembly (30FT)

Mount wing frames to center frame.

**NOTE:** Following illustration shows left wing axle installation. Right wing axle is attached in the same manner.

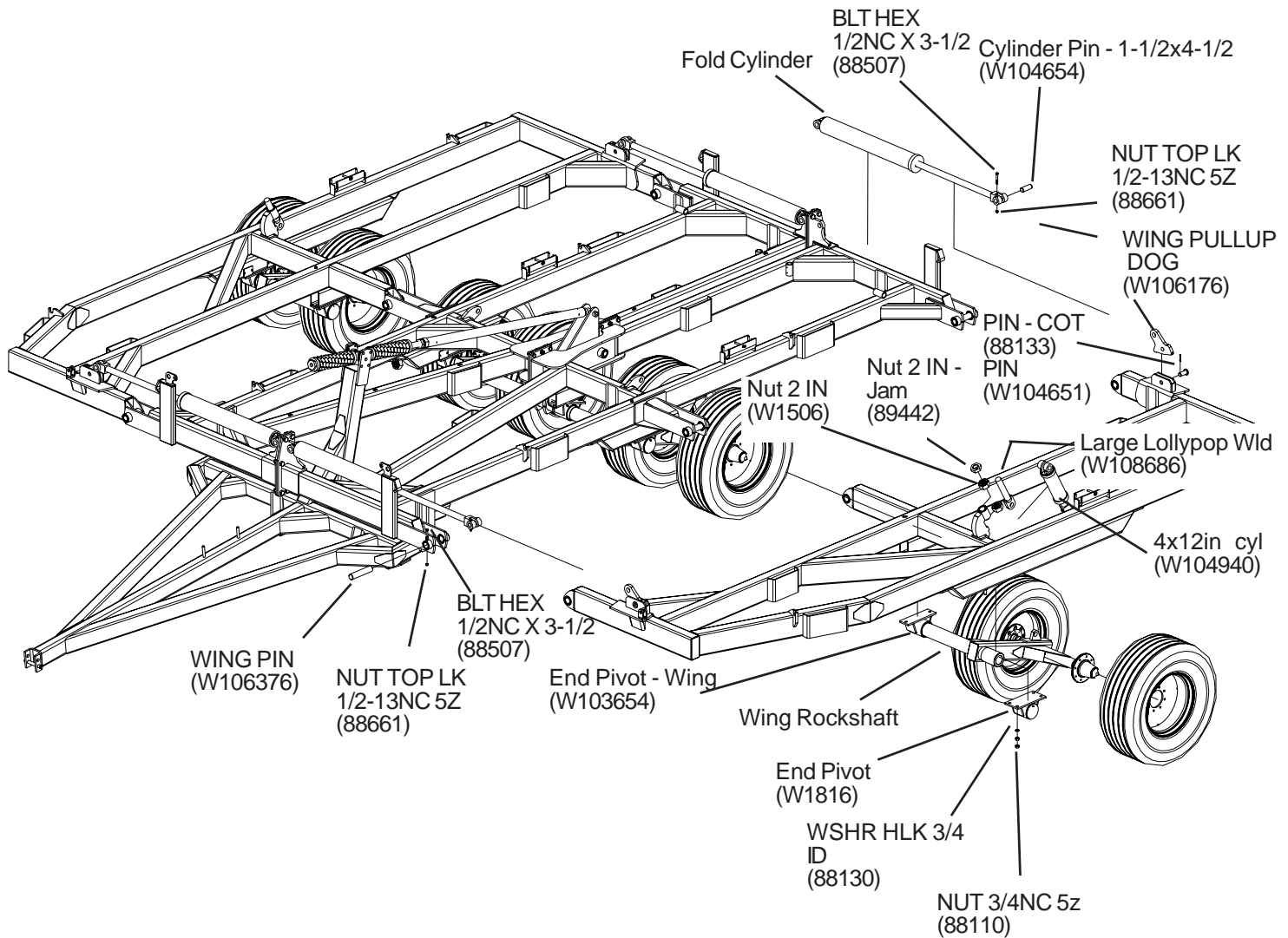

Left Wing Frame - Shown

	<p><b>⚠ DANGER</b></p> <p><b>STAND CLEAR AT ALL TIMES</b></p>	<ul style="list-style-type: none"> <li>• Never walk or stand in the path of the wings.</li> <li>• Completely lower wings before performing service or adjustments.</li> <li>• Failure to do so will result in serious injury or death.</li> </ul> <p style="text-align: right; font-size: small;">222800</p>
--	---	--

## Step 7 - Hydraulics

Install hydraulic cylinder, fittings, and hoses. Use the steps below as a guide to follow.

1. Attach hitch to tractor drawbar.
2. See illustration on next pages for correct placement of the hoses.
3. Fasten the remaining hydraulic hoses from the cylinders to the tee fittings and the hoses from the tee's to the tractor. There is a 1/2" male pipe fitting at the end of the hoses leading to the tractor. Pioneer Quick Coupler fittings required to attach the hoses to the tractor are furnished.
4. Install hydraulic cylinders to the machine, with the base of the cylinder attaching to the center frame. Be sure the bolts through the mounting pins are securely on the pin to prevent the pin from falling out.
5. Stroke cylinders to full length several times to allow oil to fill both cylinders and hoses.
6. Check all hydraulic components and connections for leaks. Replace any hoses or fittings that develop leaks.



**CAUTION:** Do not connect or disconnect hydraulic components when there is pressure within the system. Hydraulic systems are highly pressurized. Escaping hydraulic oil, even an invisible pinhole leak, can penetrate body tissues and cause serious injury. Use a piece of wood or cardboard when looking for leaks. Never use the hands or other parts of the body. When reassembling, make absolutely certain that all connections are tight. If injured by hydraulic oil escaping under pressure, see a doctor immediately. Serious infection or reaction may occur if medical attention is not

## Step 7 -Hydraulics (Depth Control 22FT/26FT)

### Hydraulic hose layout for machine depth control.



#### CAUTION

Before field operations, cycle hydraulic system several times to purge system of air, and ensure system is sequenced. Be sure area is clear of debris and people before operation.

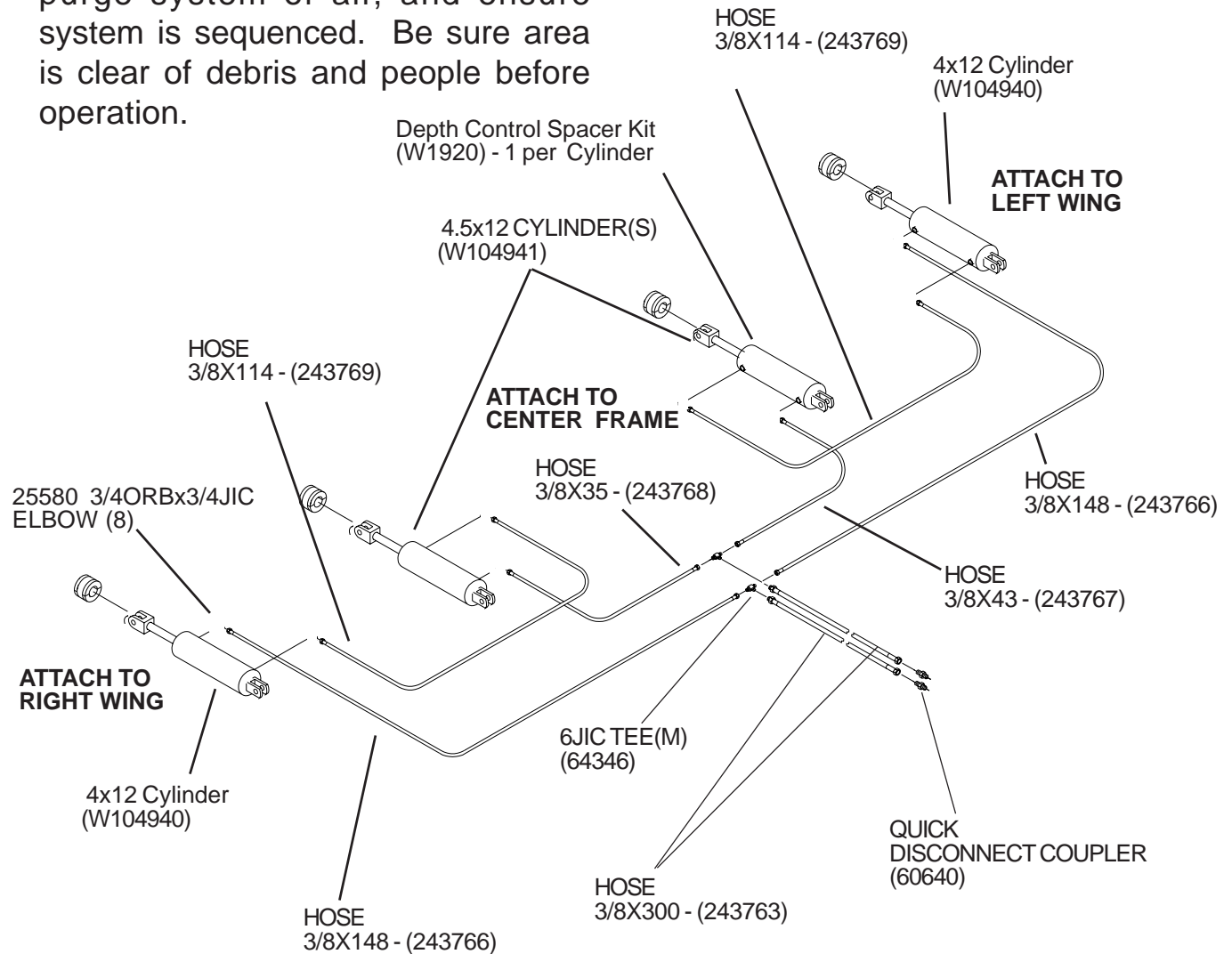



## Step 7 -Hydraulics (Depth Control 30FT)

### Hydraulic hose layout for machine depth control.



#### CAUTION

Before field operations, cycle hydraulic system several times to purge system of air, and ensure system is sequenced. Be sure area is clear of debris and people before operation.

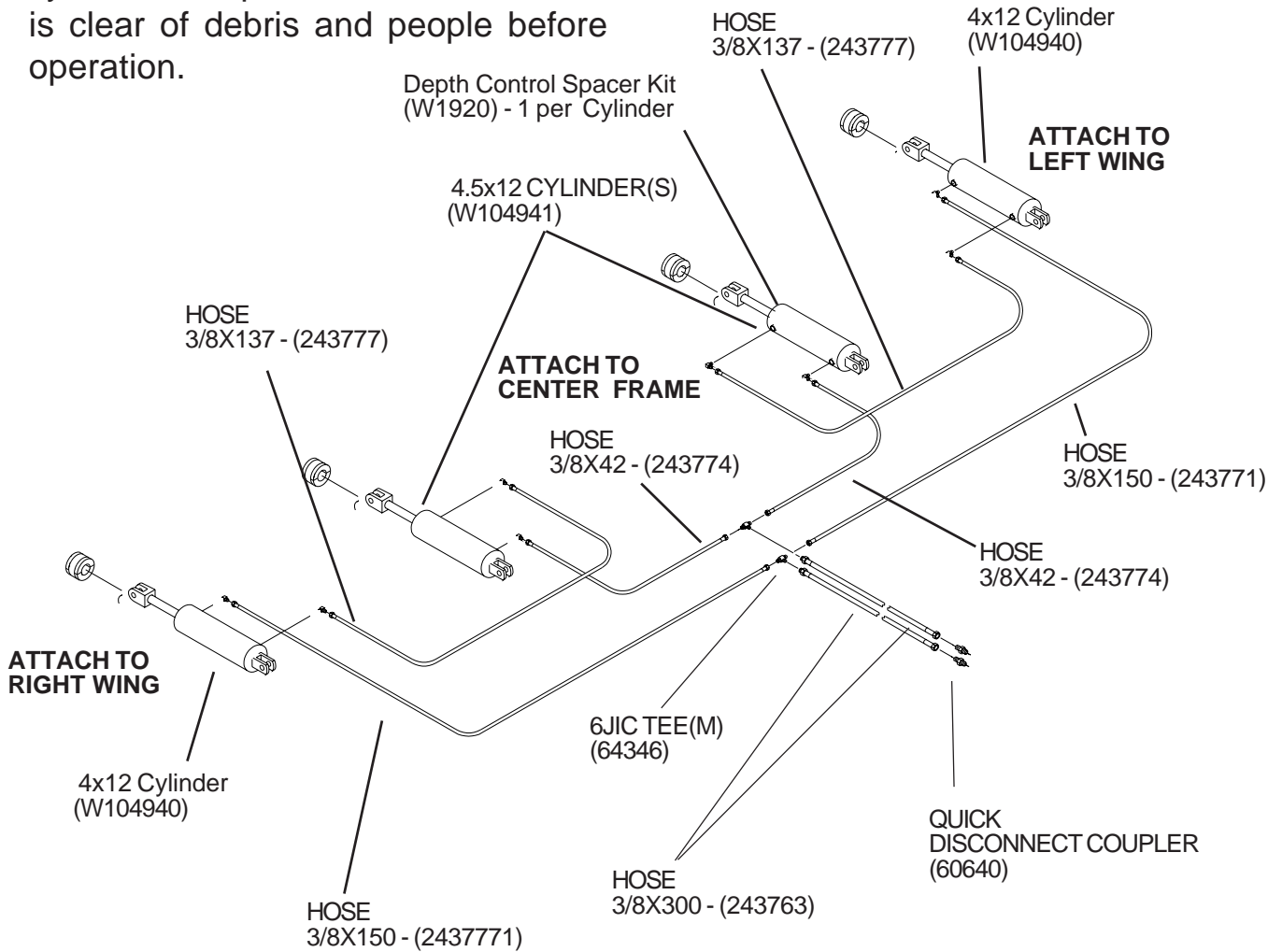

## Step 7 - Hydraulics (Wing Fold 22FT/26FT)



### CAUTION

Before attaching cylinders to disc stroke cylinders to full length several times to allow oil to fill the cylinder, otherwise cylinders may drop load when first used.

### Hydraulic hose layout for single wing fold cylinders.

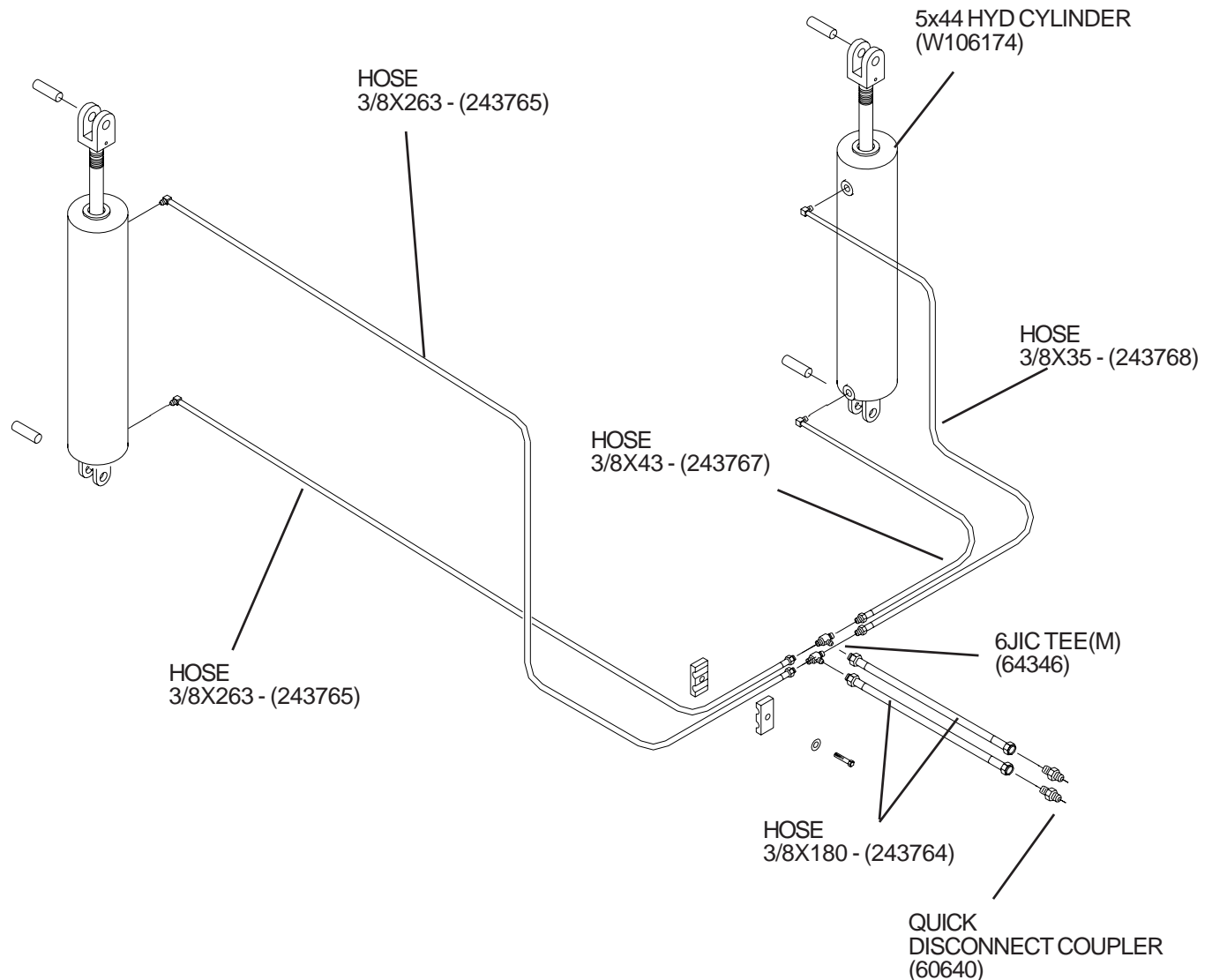

**CAUTION:** Do not connect or disconnect hydraulic components when there is pressure within the system. Hydraulic systems are highly pressurized. Escaping hydraulic oil, even an invisible pinhole leak, can penetrate body tissues and cause serious injury. Use a piece of wood or cardboard when looking for leaks. Never use the hands or other parts of the body. When reassembling, make absolutely certain that all connections are tight. If injured by hydraulic oil escaping under pressure, see a doctor immediately. Serious infection or reaction may occur if medical attention is not received at once.



## CAUTION

Before attaching cylinders to disc stroke cylinders to full length several times to allow oil to fill the cylinder, otherwise cylinders may drop load when first used.

## Hydraulic hose layout for double wing fold cylinders.

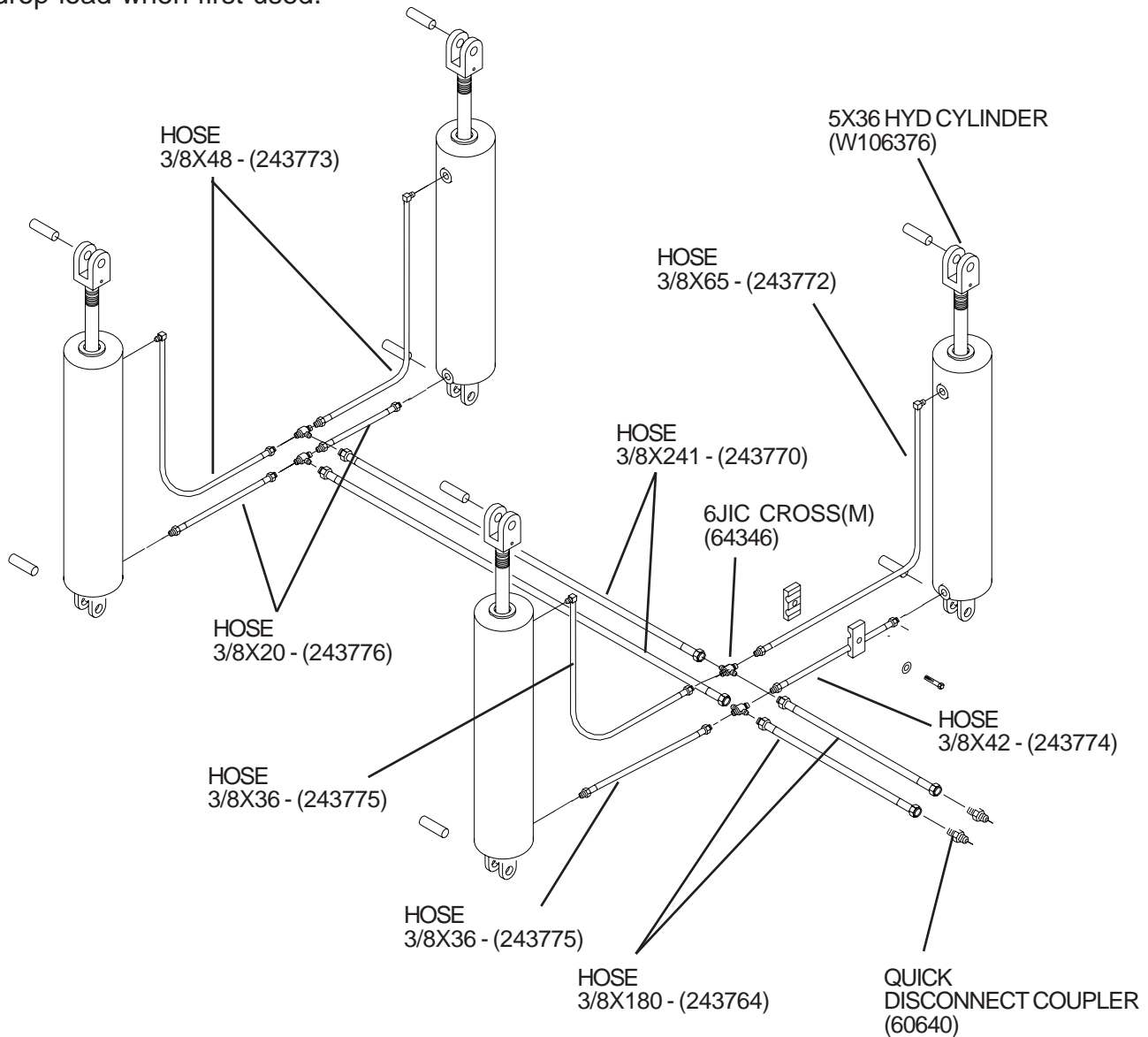

**CAUTION:** Do not connect or disconnect hydraulic components when there is pressure within the system. Hydraulic systems are highly pressurized. Escaping hydraulic oil, even an invisible pinhole leak, can penetrate body tissues and cause serious injury. Use a piece of wood or cardboard when looking for leaks. Never use the hands or other parts of the body. When reassembling, make absolutely certain that all connections are tight. If injured by hydraulic oil escaping under pressure, see a doctor immediately. Serious infection or reaction may occur if medical attention is not received at once.

# Step 7 - Hydraulics (Hose Clamp)



## CAUTION

Before attaching cylinders to disc stroke cylinders to full length several times to allow oil to fill the cylinder, otherwise cylinders may drop load when first used.

- 3/8NCx1-1/4 Gr5 - (88555)
- 3/8NCx2-1/4 Gr5 - (88581)
- 3/8IN Washer (88282)
- HOSE CLAMP (W105784)

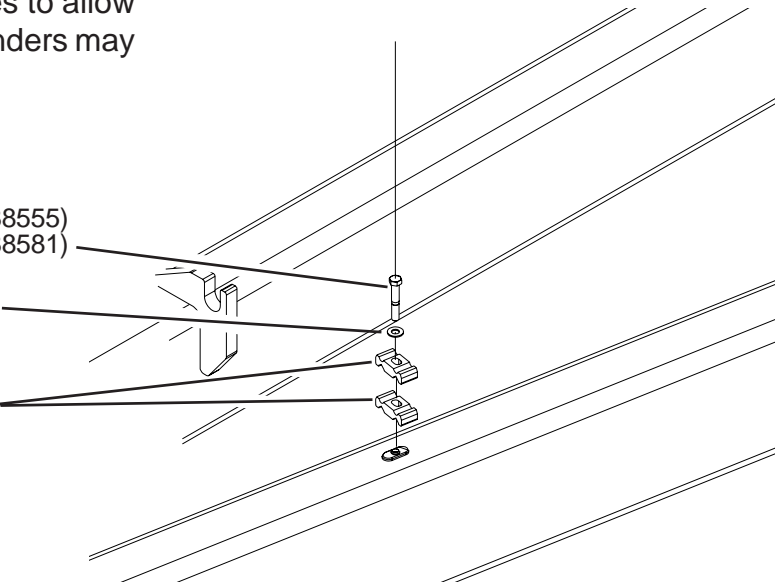

Route hoses in a fashion that does not allow field trash or crop debris to become entangled or cause premature wear on hoses. Be aware of how hoses bend in fold locations.

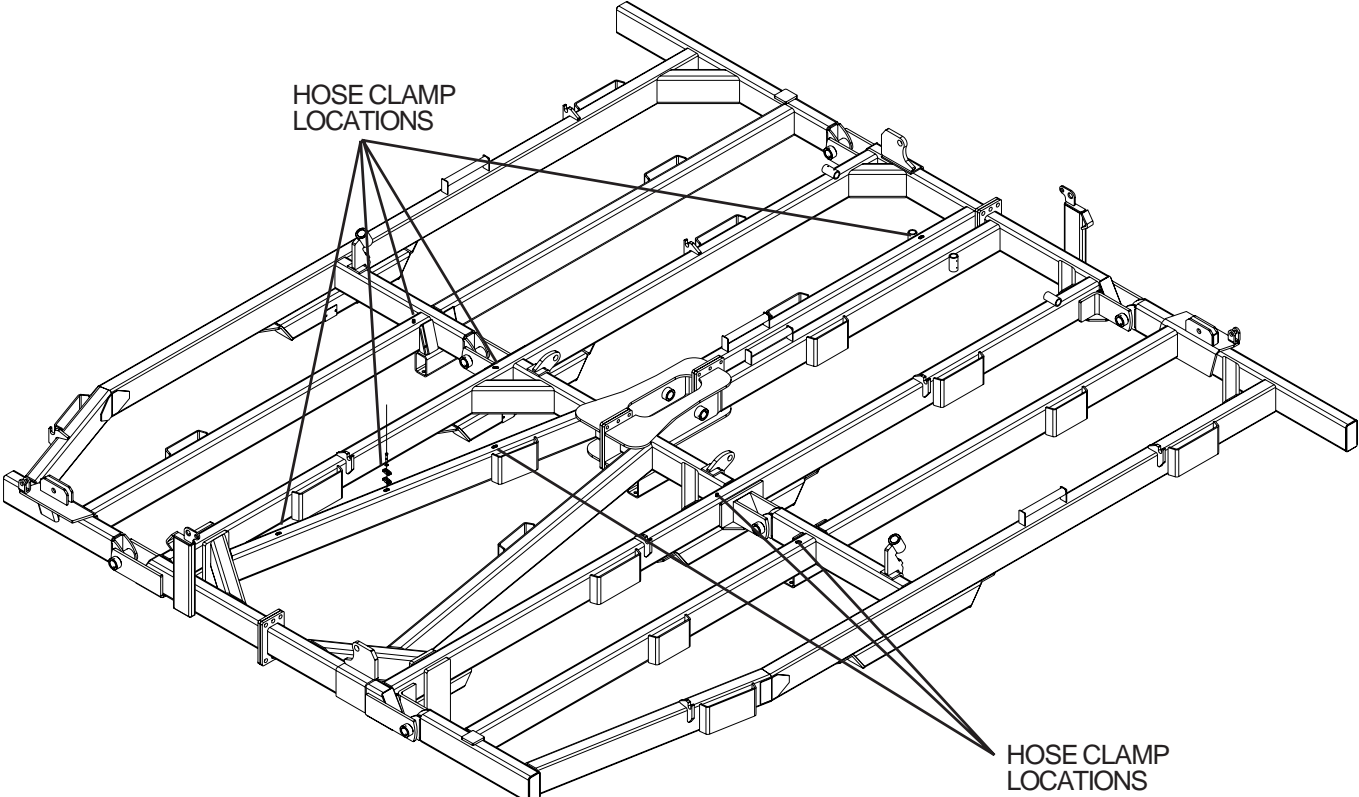

# Step 8 - Gang Assembly

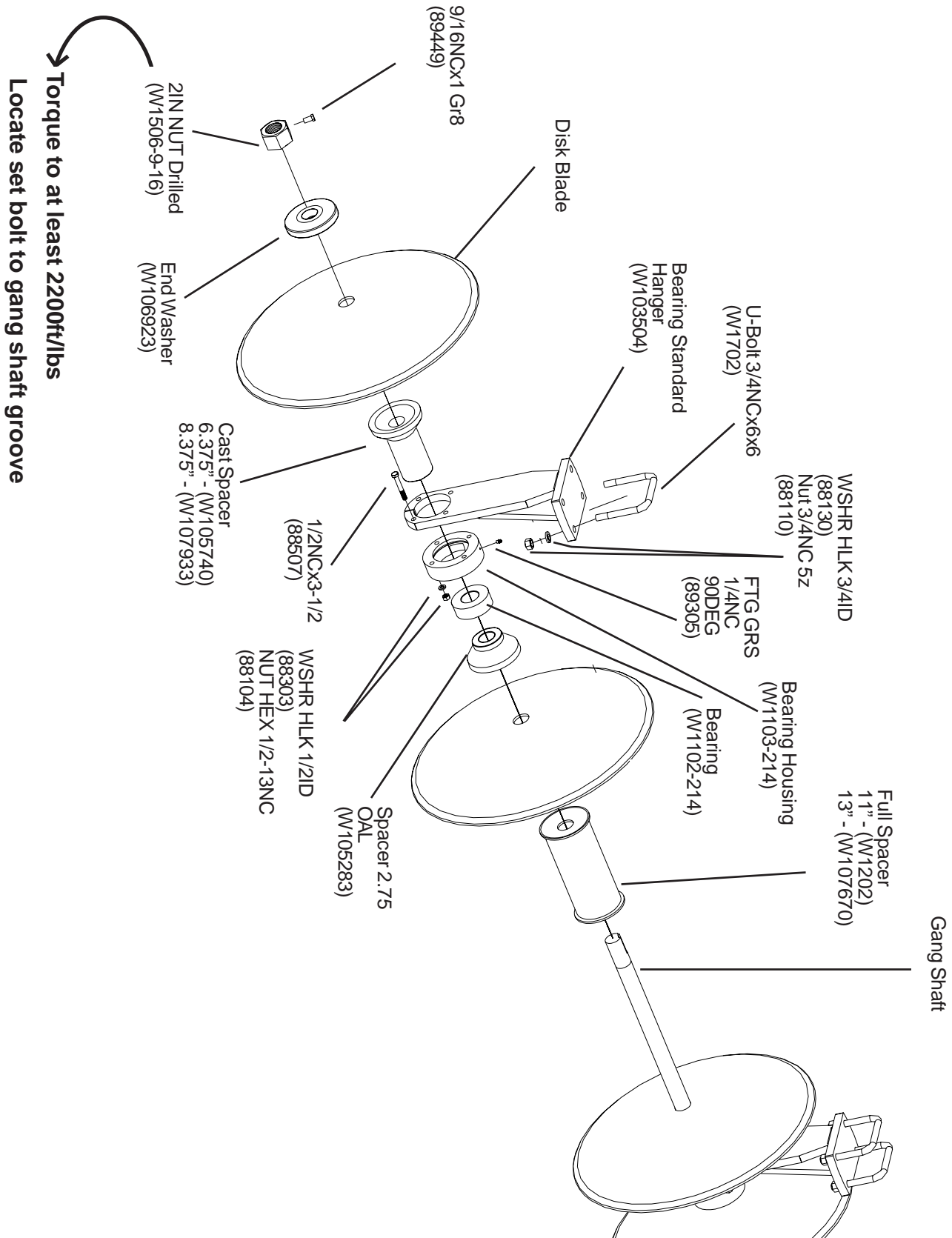

## Step 8 - Bearing Stand Alignment

Check the following items while mounting the gangs to the machine. If the bearing stands are improperly installed, side loads will be created on the gang bearings which can cause the bearing to fail prematurely. Excessive stress is also created on other parts of the machine.

**Follow these steps and illustrations in installing the gang assemblies for proper set-up**

1. Place a gang assembly under frame in approximate location. For information on locations of the different gangs see pages 51-59.
2. Fasten one bearing stand by using two 3/4" diameter U-bolts, lockwashers and nuts, starting on either end of the gang. Tighten to gang beam.
3. Continue to the next bearing stand and tighten with same hardware as before. Tightening bearing stands from one side of gang to the other ensures that no side load is put on the bearing.
4. Check the complete assembly to see that all bearing stands are installed properly and that all bolts are tight.

## Step 9 - Gang Assembly

Install spring buckets to crosstube. Use three 3/4" U-bolts with lockwashers and nuts per bucket. The buckets must be located to match ear locations on rabbit ear tubes. Next, the spring trip assembly (842NT or 862NT models) must be assembled in fashion illustrated below.

To assemble gang units to the machine see number printed on gang tube and reference to correct gang layout found later in manual.



**CAUTION:** Do **NOT** install rear gangs on a section before all front gangs are mounted. A dangerous tipping situation could result.



**CAUTION:** When working on disc, care should be exercised in handling or tightening bolts near disc blades to avoid injury.

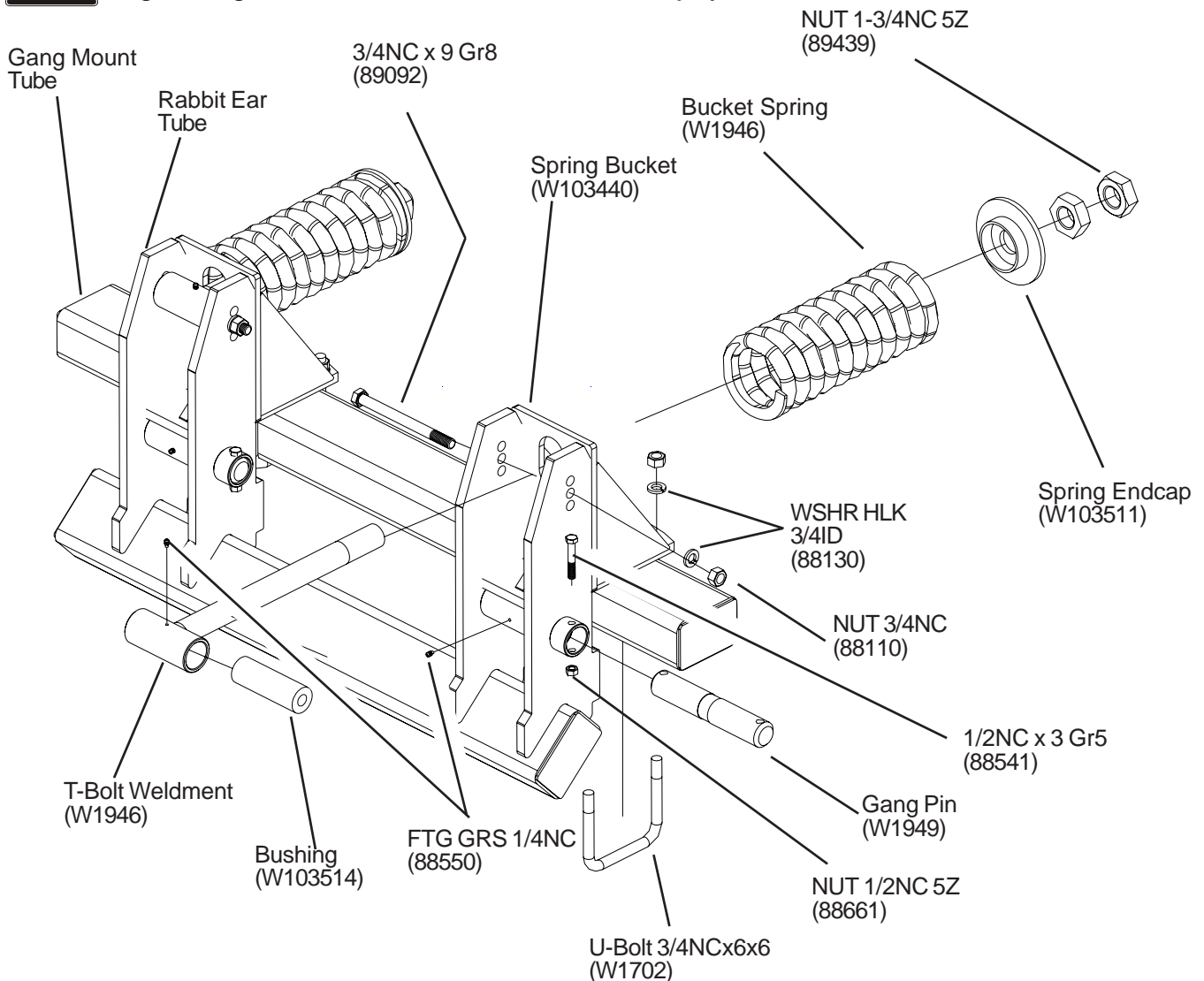

**NOTE: ONLY USED ON 842NT  
AND 862NT MODELS**



## Step 9 - Gang Assembly

To install gang assemblies to the frame, locate welded gang positioning stud inside of pocket located on disc frame. Place caster clamp around gang tube into the frame pocket and attach using 1-3/4" nut and washer as illustrated below.

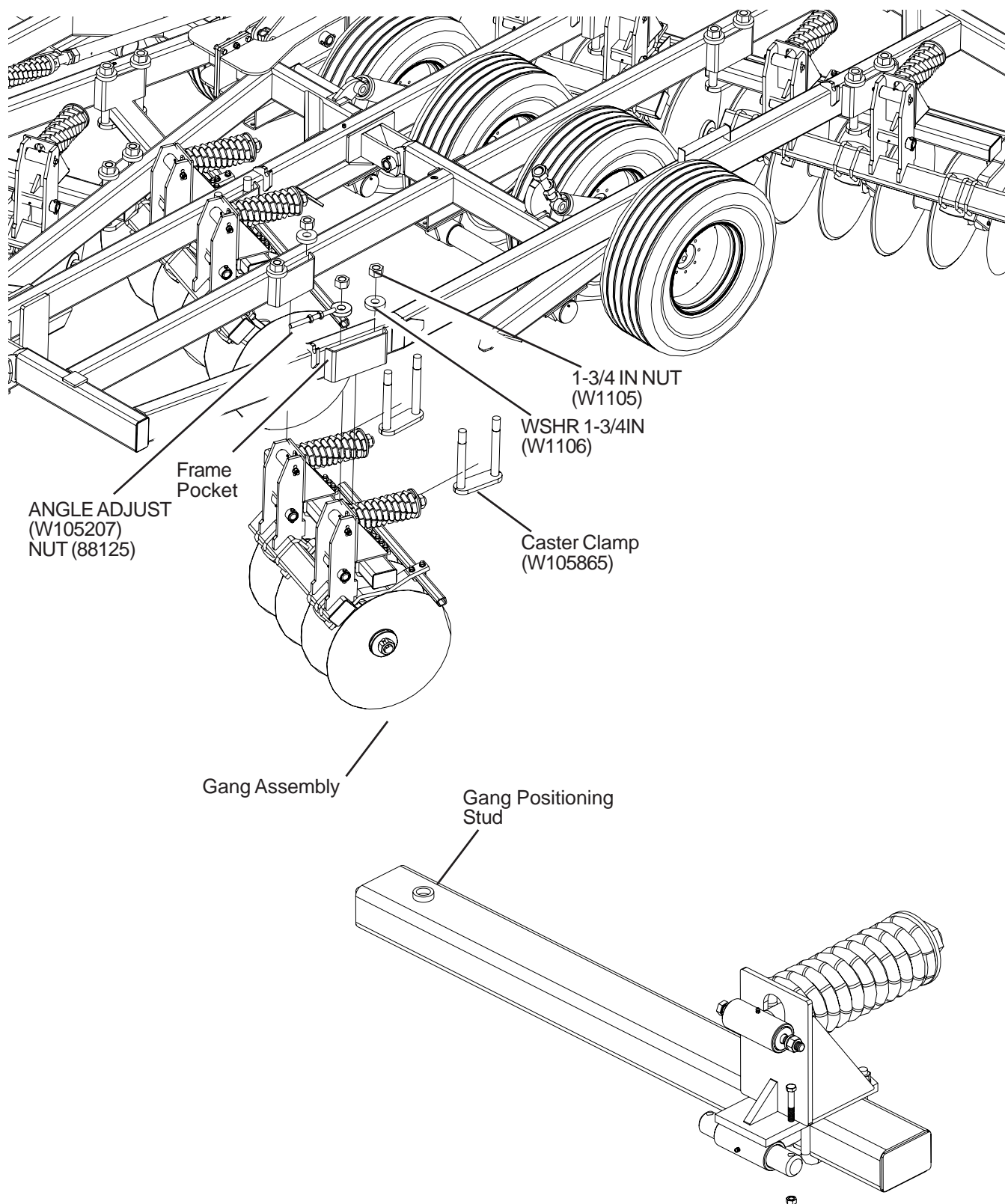

## Step 9 - Gang Assembly



**CAUTION:** Do **NOT** install rear gangs on a section before all front gangs. A dangerous tipping situation could result.



**CAUTION:** When working on disc, care should be exercised in handling or tightening bolts near disc blades to avoid injury.

### 22 FT 816NT GANG LAYOUT

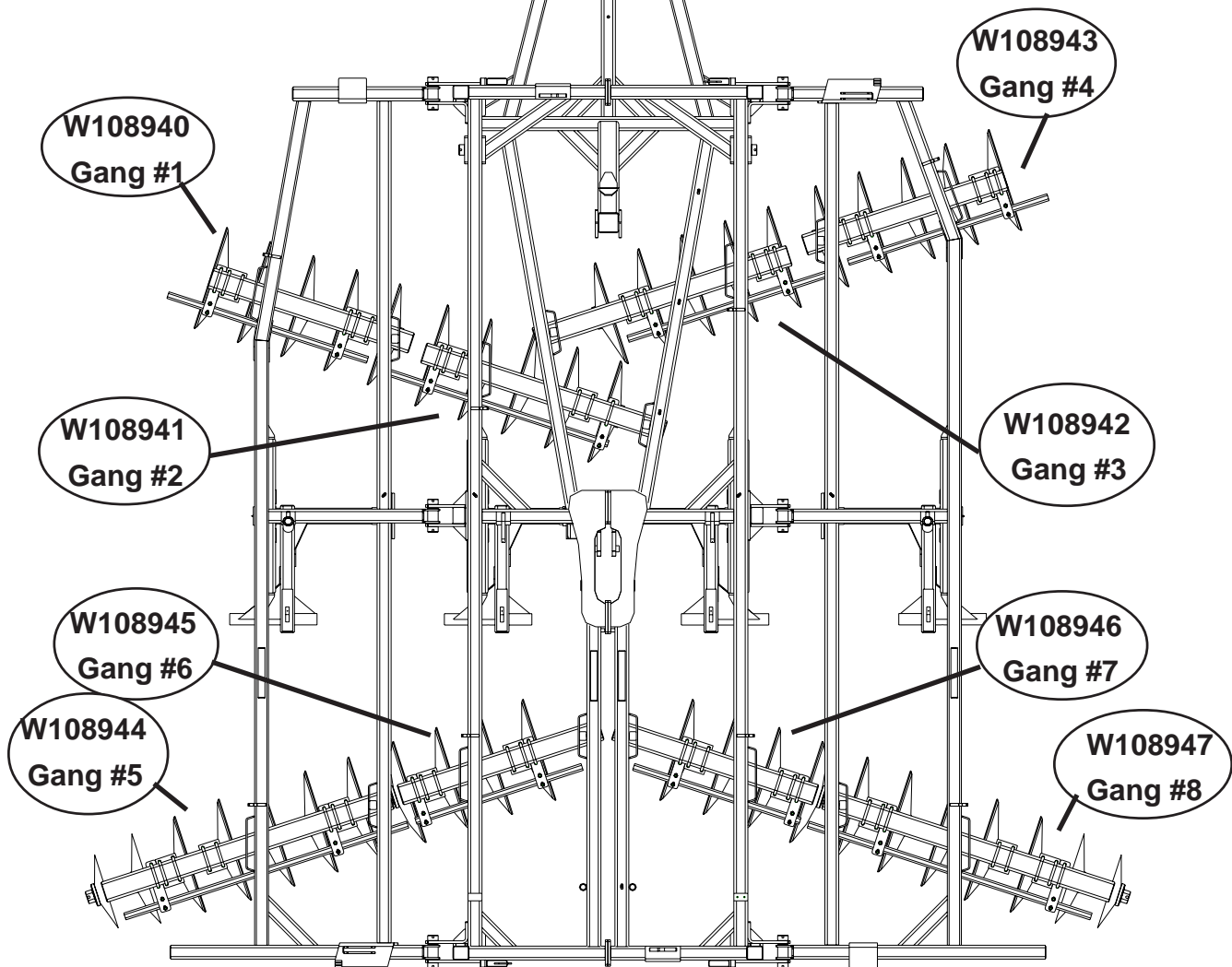

**NOTE:** Maintain 13.5" spacing between MF and wing gangs

## Step 9 - Gang Assembly



**CAUTION:** Do **NOT** install rear gangs on a section before all front gangs are mounted. A dangerous tipping situation could result.



**CAUTION:** When working on disc, care should be exercised in handling or tightening bolts near disc blades to avoid injury.

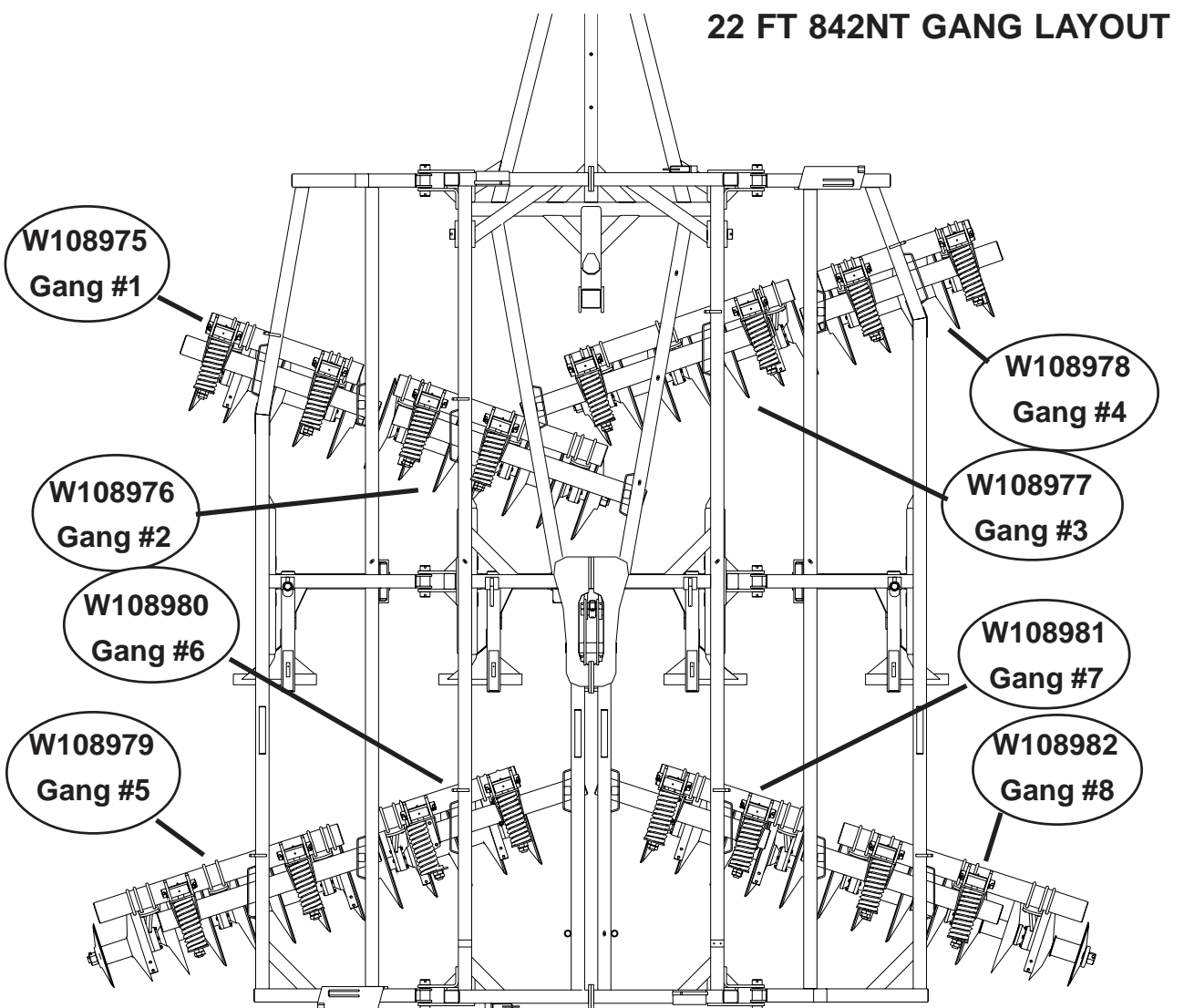

**NOTE:** Maintain 11.5" spacing between MF and wing gangs

## Step 9 - Gang Assembly



**CAUTION:** Do **NOT** install rear gangs on a section before all front gangs. A dangerous tipping situation could result.



**CAUTION:** When working on disc, care should be exercised in handling or tightening bolts near disc blades to avoid injury.

### 22 FT 862NT GANG LAYOUT

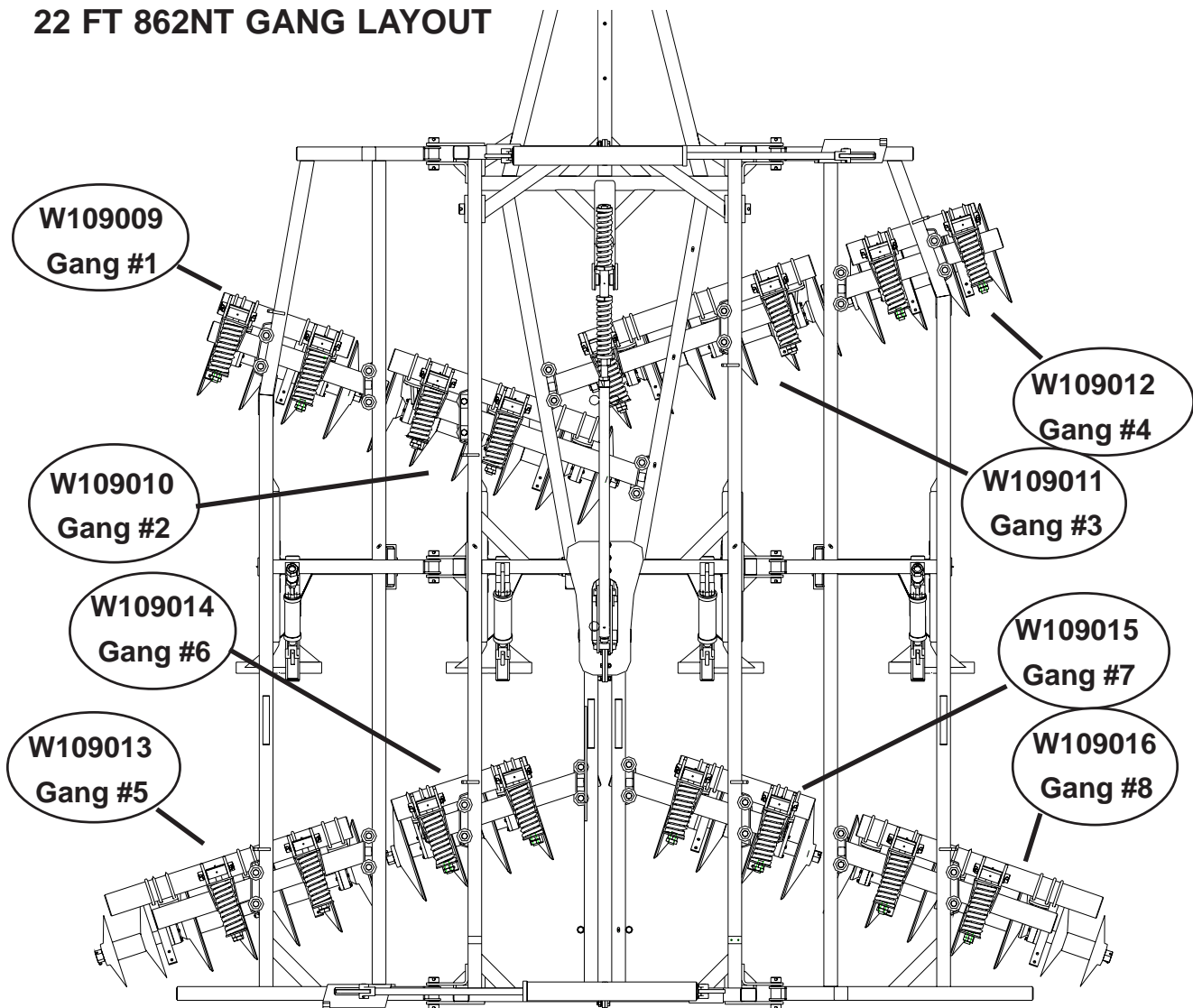

**NOTE:** Maintain 13.5" spacing between MF and wing gangs

## Step 9 - Gang Assembly



**CAUTION:** Do **NOT** install rear gangs on a section before all front gangs. A dangerous tipping situation could result.



**CAUTION:** When working on disc, care should be exercised in handling or tightening bolts near disc blades to avoid injury.

### 26 FT 842NT GANG LAYOUT

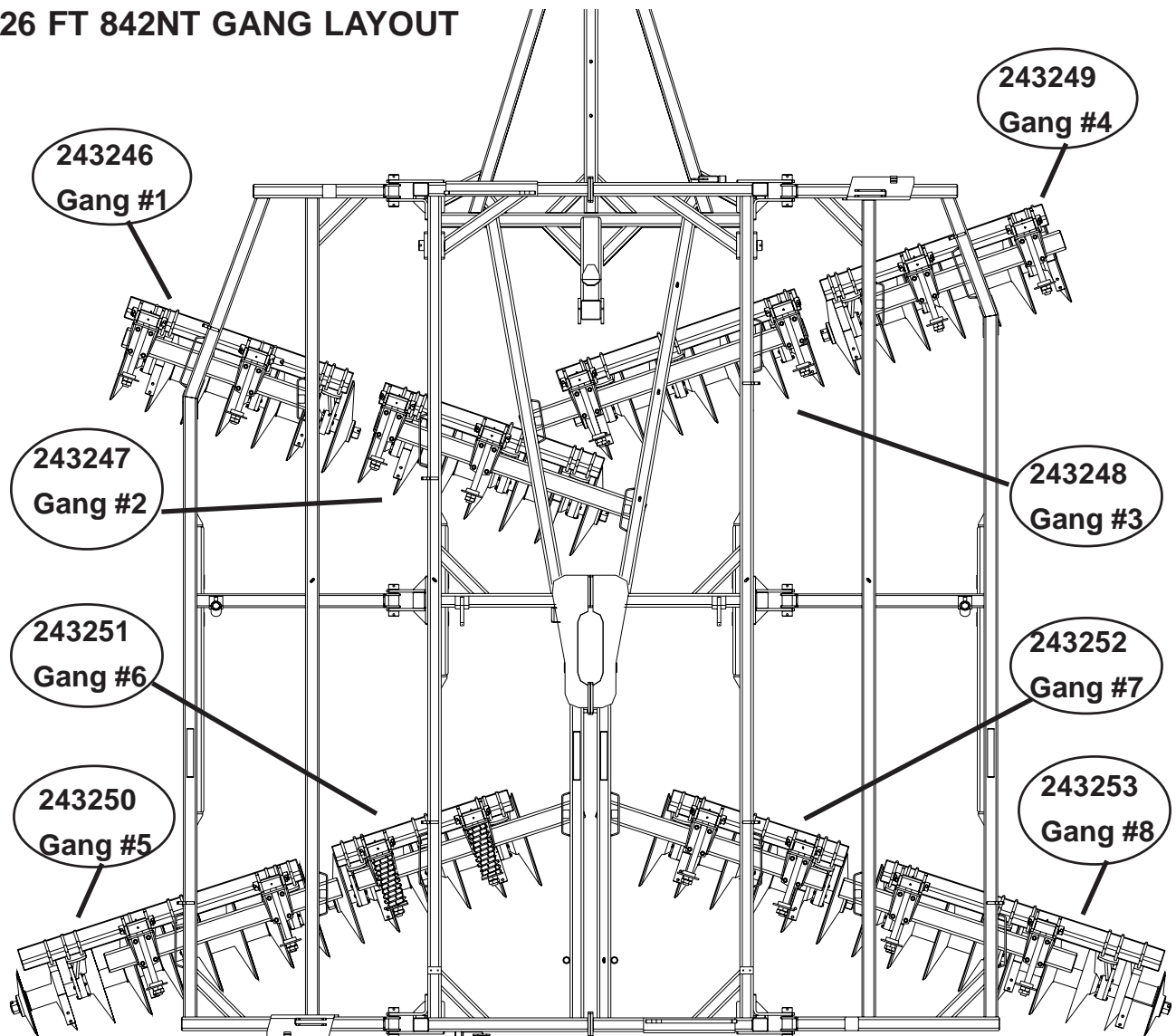

**NOTE:** Maintain 11.5" spacing between MF and wing gangs

## Step 9 - Gang Assembly



**CAUTION:** Do **NOT** install rear gangs on a section before all front gangs. A dangerous tipping situation could result.



**CAUTION:** When working on disc, care should be exercised in handling or tightening bolts near disc blades to avoid injury.

### 26 FT 862NT GANG LAYOUT

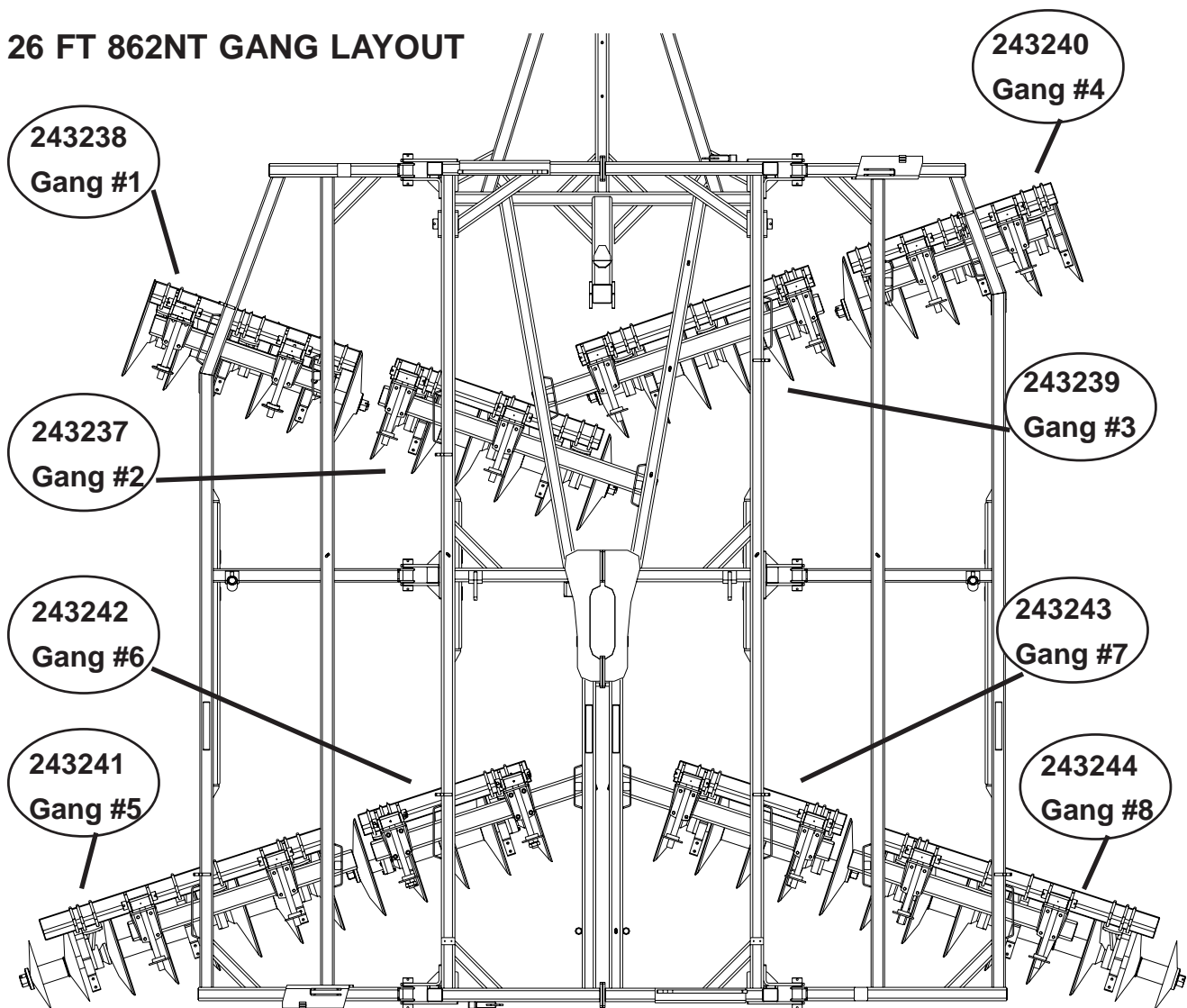

**NOTE:** Maintain 13.5" spacing between MF and wing gangs



## Step 9 - Gang Assembly



**CAUTION:** Do **NOT** install rear gangs on a section before all front gangs. A dangerous tipping situation could result.



**CAUTION:** When working on disc, care should be exercised in handling or tightening bolts near disc blades to avoid injury.

### 30FT 816NT GANG LAYOUT

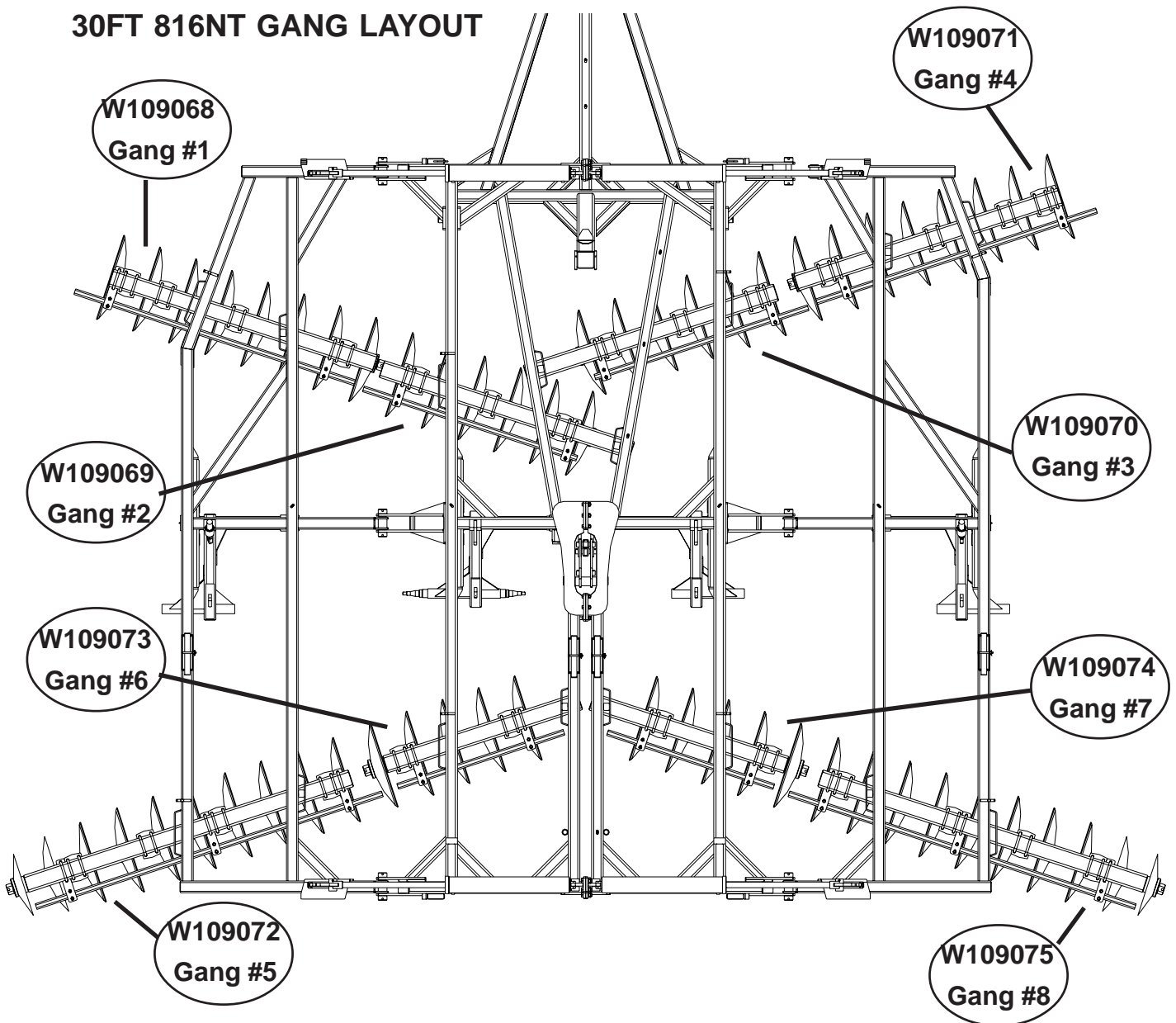

**NOTE:** Maintain 13.5" spacing between MF and wing gangs



## Step 9 - Gang Assembly



**CAUTION:** Do **NOT** install rear gangs on a section before all front gangs. A dangerous tipping situation could result.



**CAUTION:** When working on disc, care should be exercised in handling or tightening bolts near disc blades to avoid injury.

### 30 FT 842NT GANG LAYOUT

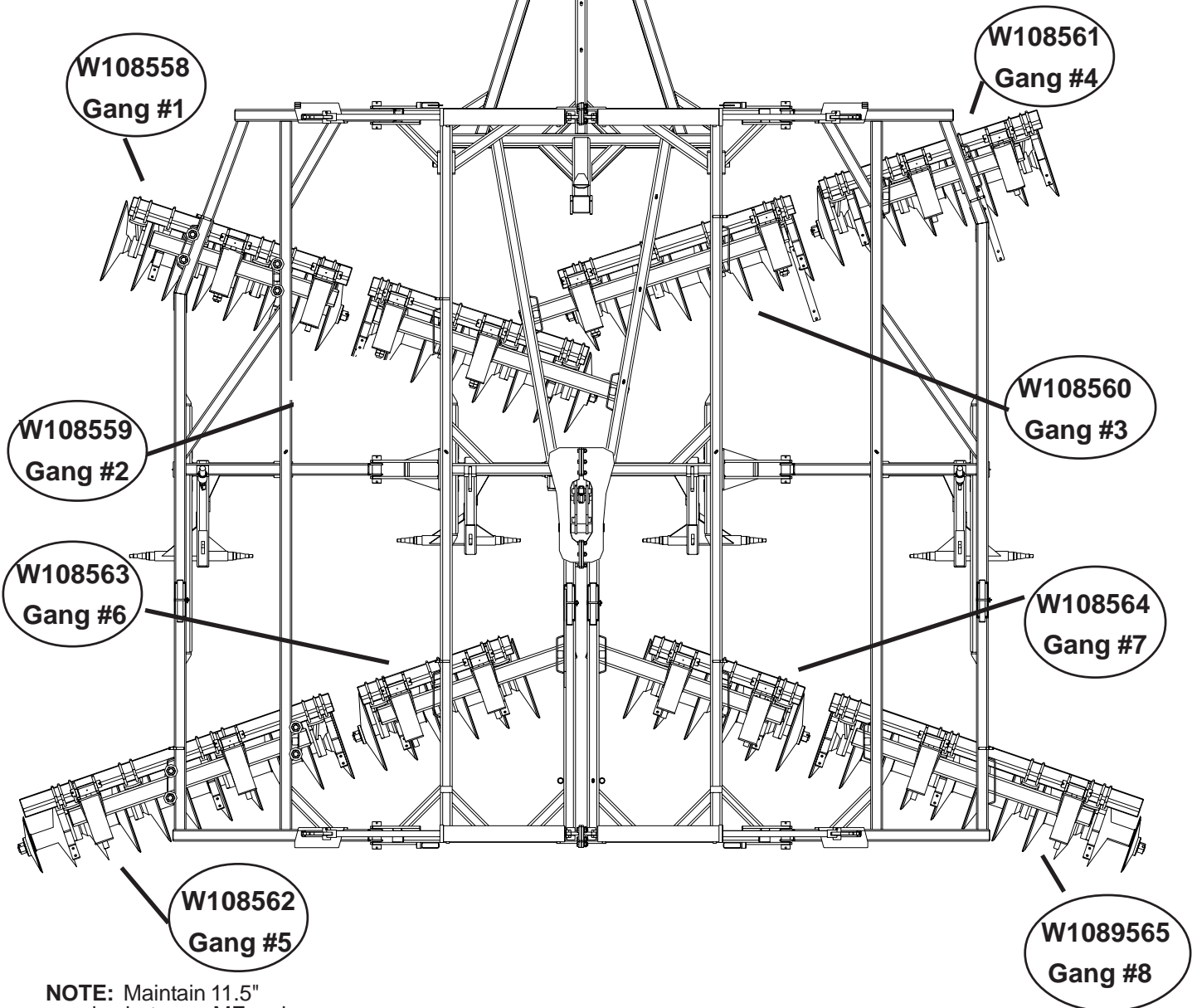

**NOTE:** Maintain 11.5" spacing between MF and wing gangs

## Step 9 - Gang Assembly



**CAUTION:** Do **NOT** install rear gangs on a section before all front gangs. A dangerous tipping situation could result.



**CAUTION:** When working on disc, care should be exercised in handling or tightening bolts near disc blades to avoid injury.

### 30 FT 862NT GANG LAYOUT

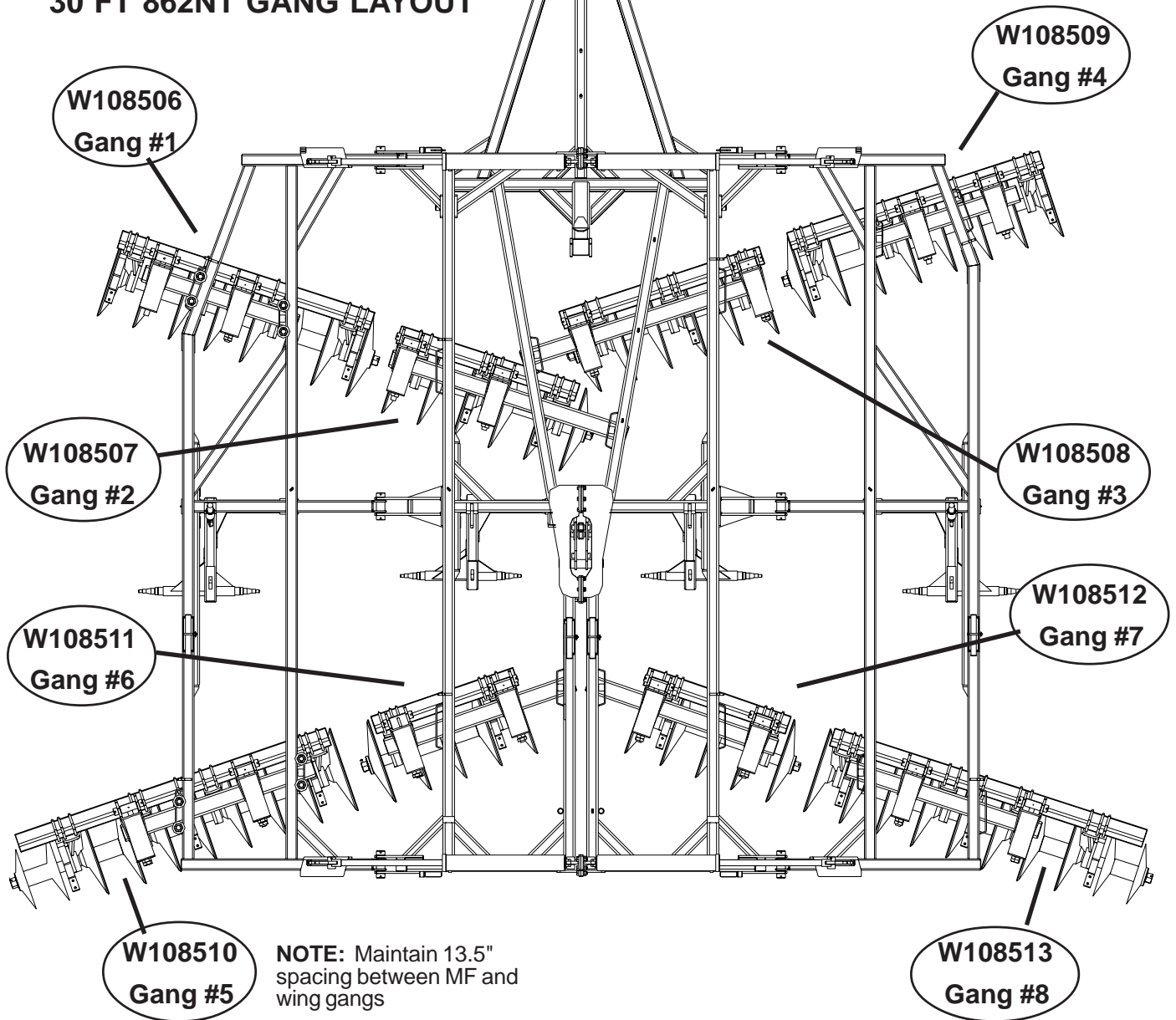

## Step 10 - Scraper Blade Attachment

Adjust the scrapers to the proper setting. Each scraper may be adjusted by loosening the scraper clamp U-bolt, and sliding the assembly along the scraper bar.

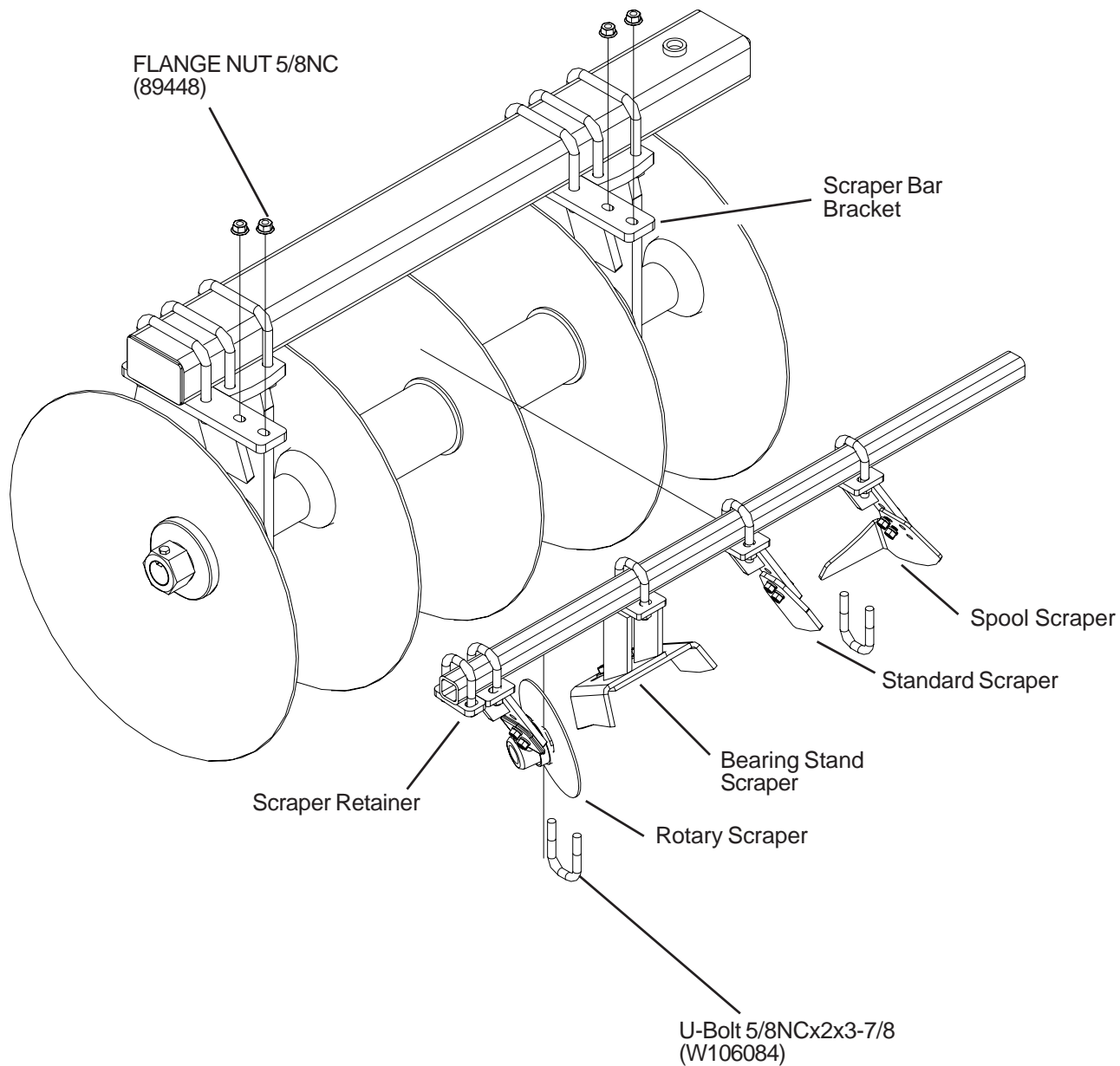

**CAUTION:** When working on disc, care should be exercised in handling or tightening bolts near disc blades to avoid injury.

# Step 10 - Standard Scraper Blade Attachment

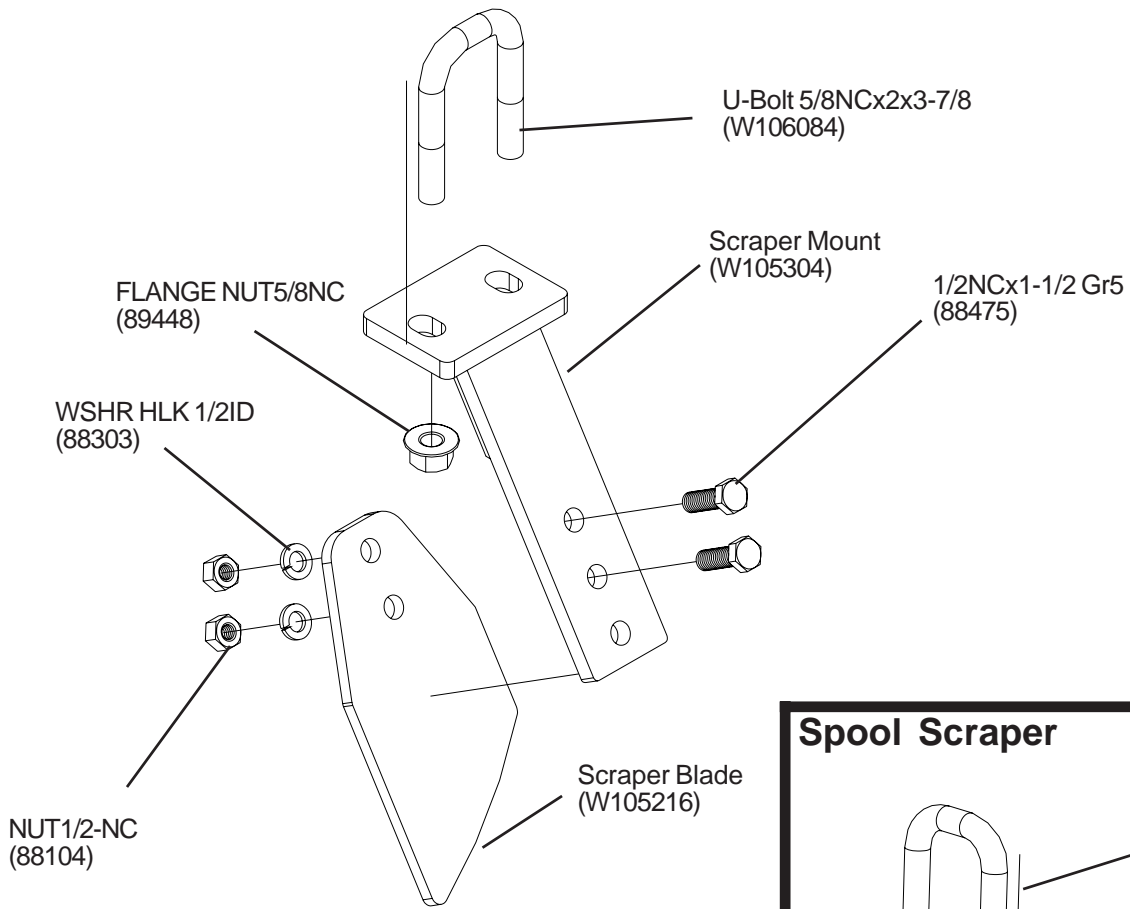

## Spool Scraper

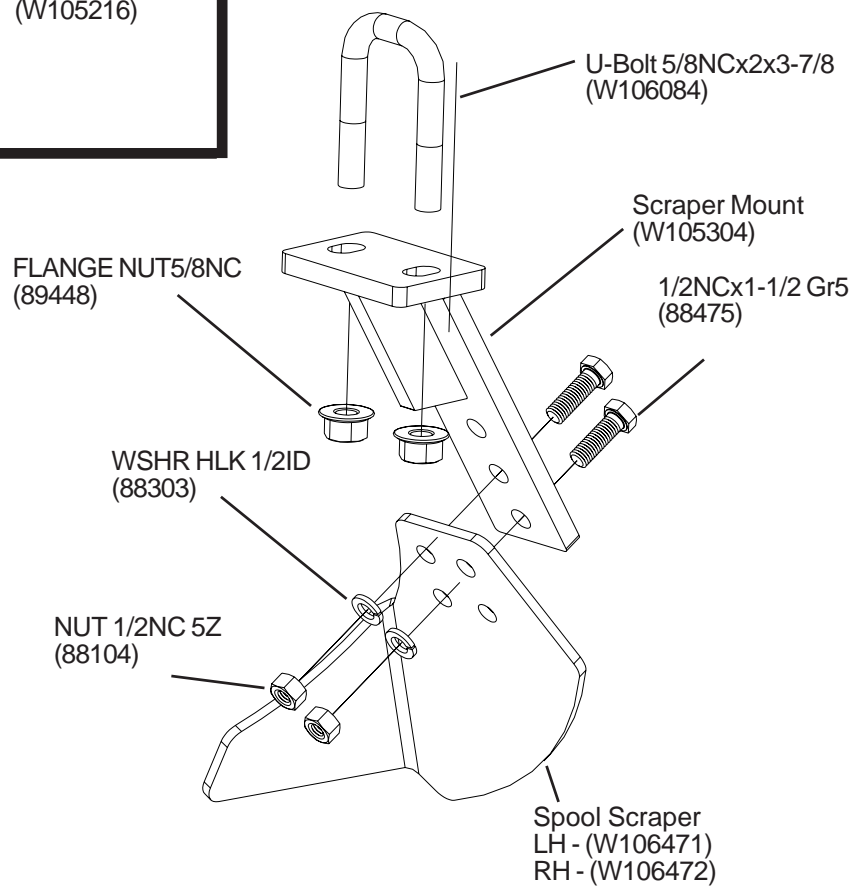

# Step 10 - Scraper Blade Attachment

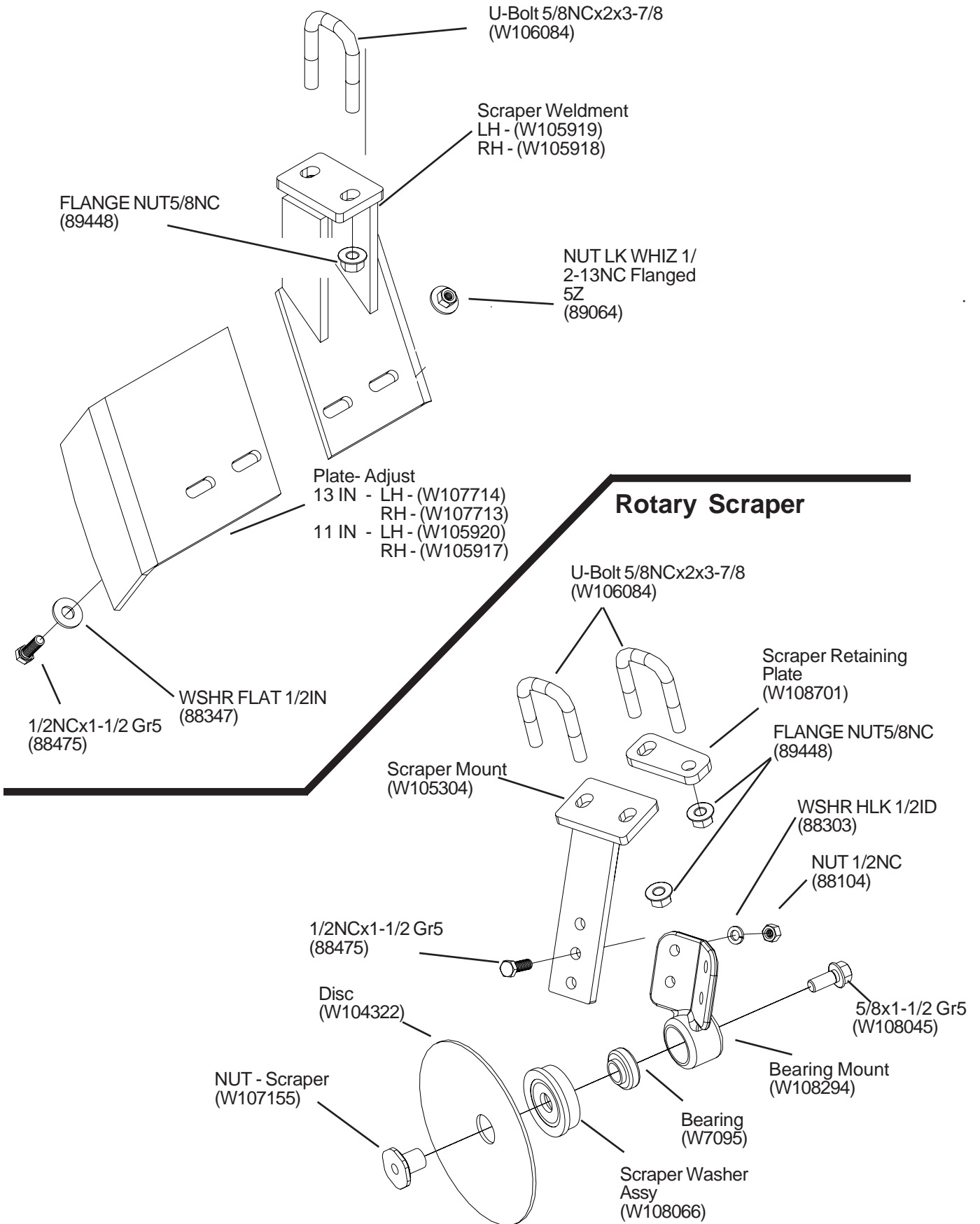

## Step 10 - Scraper Blade Attachment

### Mud Scraper

Mud scrapers are used to scrape mud from the outermost feathering blade on the rear gangs. One should be used on both the left and right side of the machine.

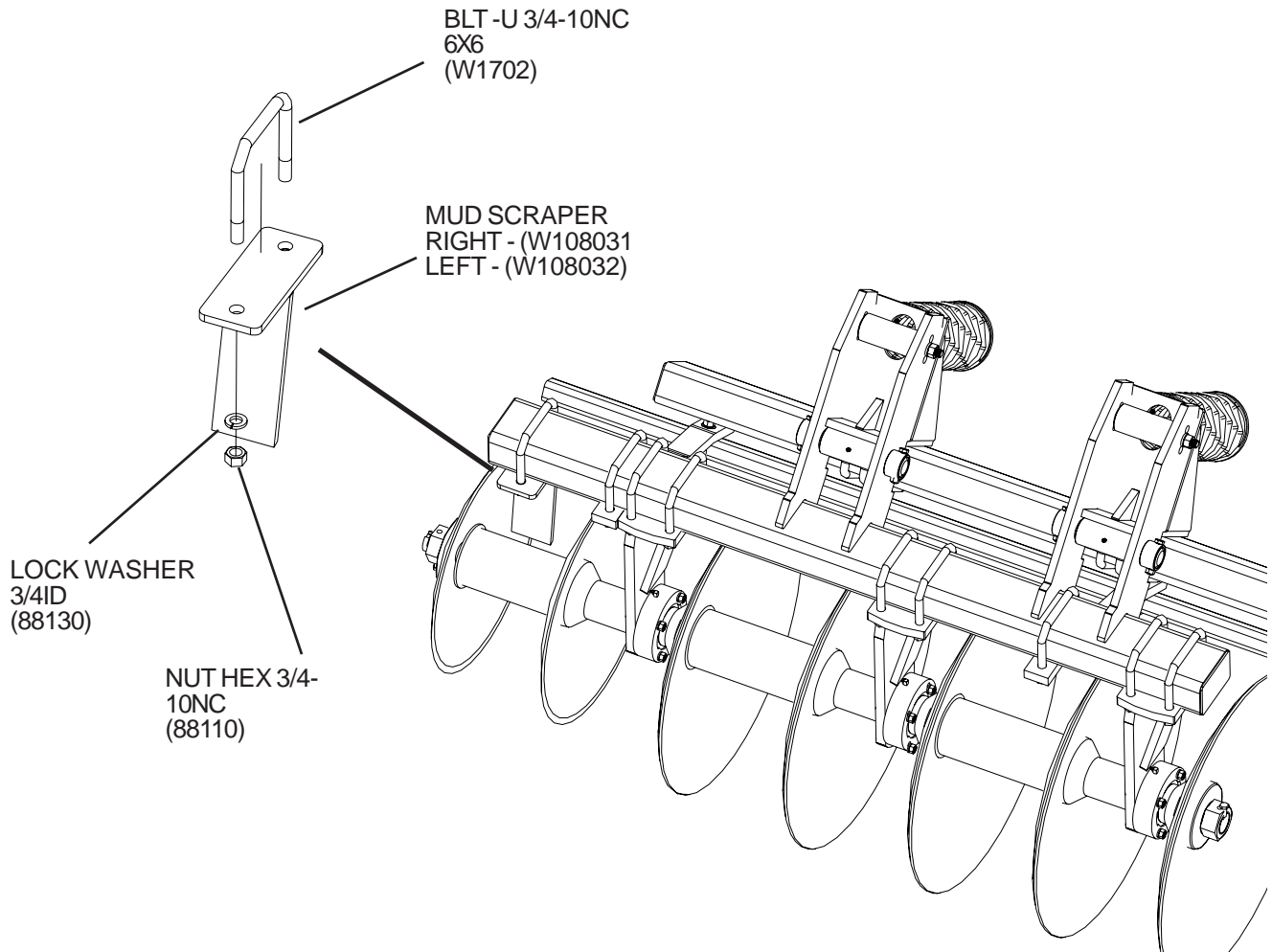

## Step 11 - Hazard Lighting Placement

**NOTE: MOUNT THE RED LIGHTS AS REARWARD AS PRACTICAL ON THE CENTER FRAME. SPACE EVENLY, 2' TO 5' FROM THE MACHINE CENTER.**

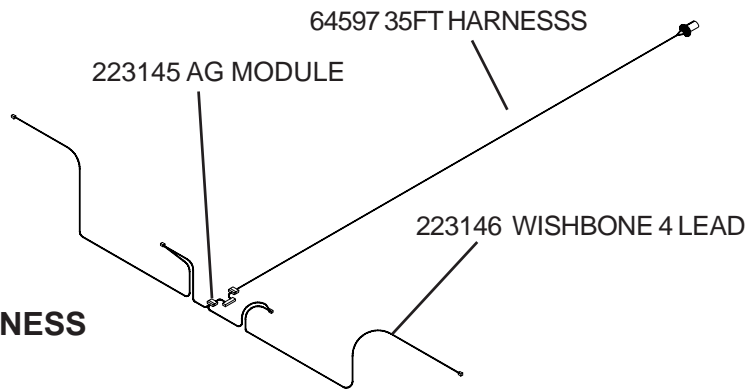

**NOTE: ROUTE LIGHT HARNESS THRU LIGHT ARMS**

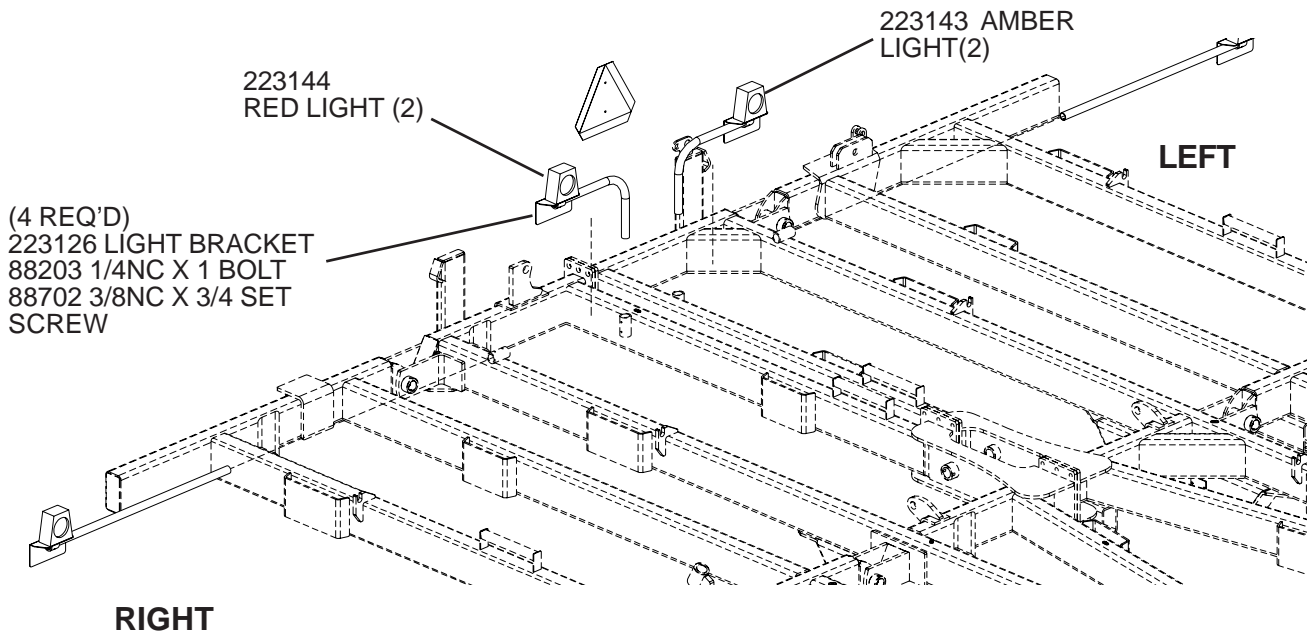

**NOTE: MOUNT AMBER LIGHTS AS WIDE AS POSSIBLE. THE AMBER LIGHTS MUST BE MOUNTED NO MORE THAN 16" FROM THE IMPLEMENT EXTREMITIES, WHEN WINGS ARE FOLDED.**

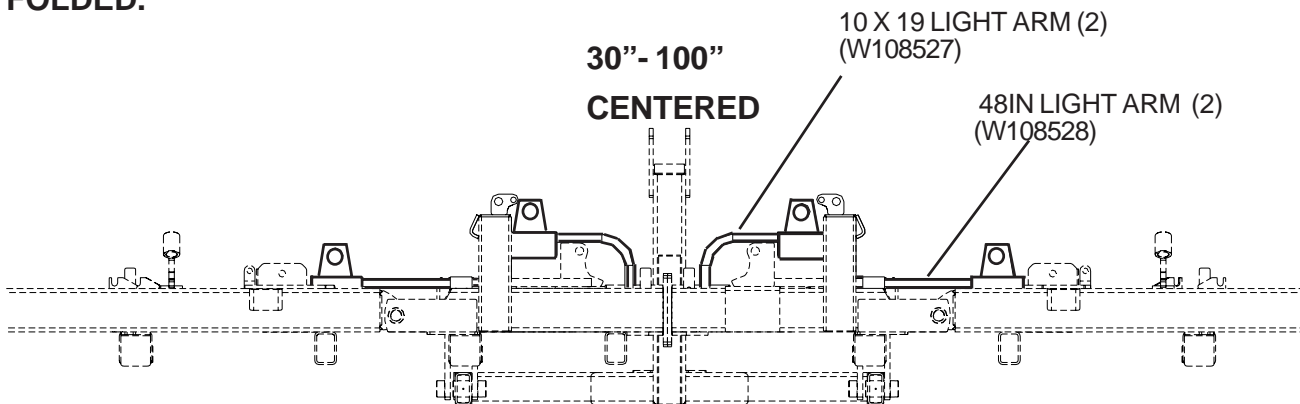



# REGISTRATION CARD

This card is to be completed and forwarded to:

# WISHEK MFG. L.L.C.

P.O. Box 185 Wishek, ND 58495-0185

UNIT MODEL NUMBER \_\_\_\_\_

UNIT SERIAL NUMBER \_\_\_\_\_

PURCHASERS NAME \_\_\_\_\_

ADDRESS \_\_\_\_\_

TELEPHONE (        ) \_\_\_\_\_

DATE OF PURCHASE \_\_\_\_\_

## DEALER NAME, ADDRESS & PHONE NUMBER

\_\_\_\_\_

\_\_\_\_\_

\_\_\_\_\_

\_\_\_\_\_

SALESPERSON \_\_\_\_\_

Cut along dotted line after completion and return  
to the manufacturer upon purchase