

WISHEK STRAW PRESS

PARTS BOOK

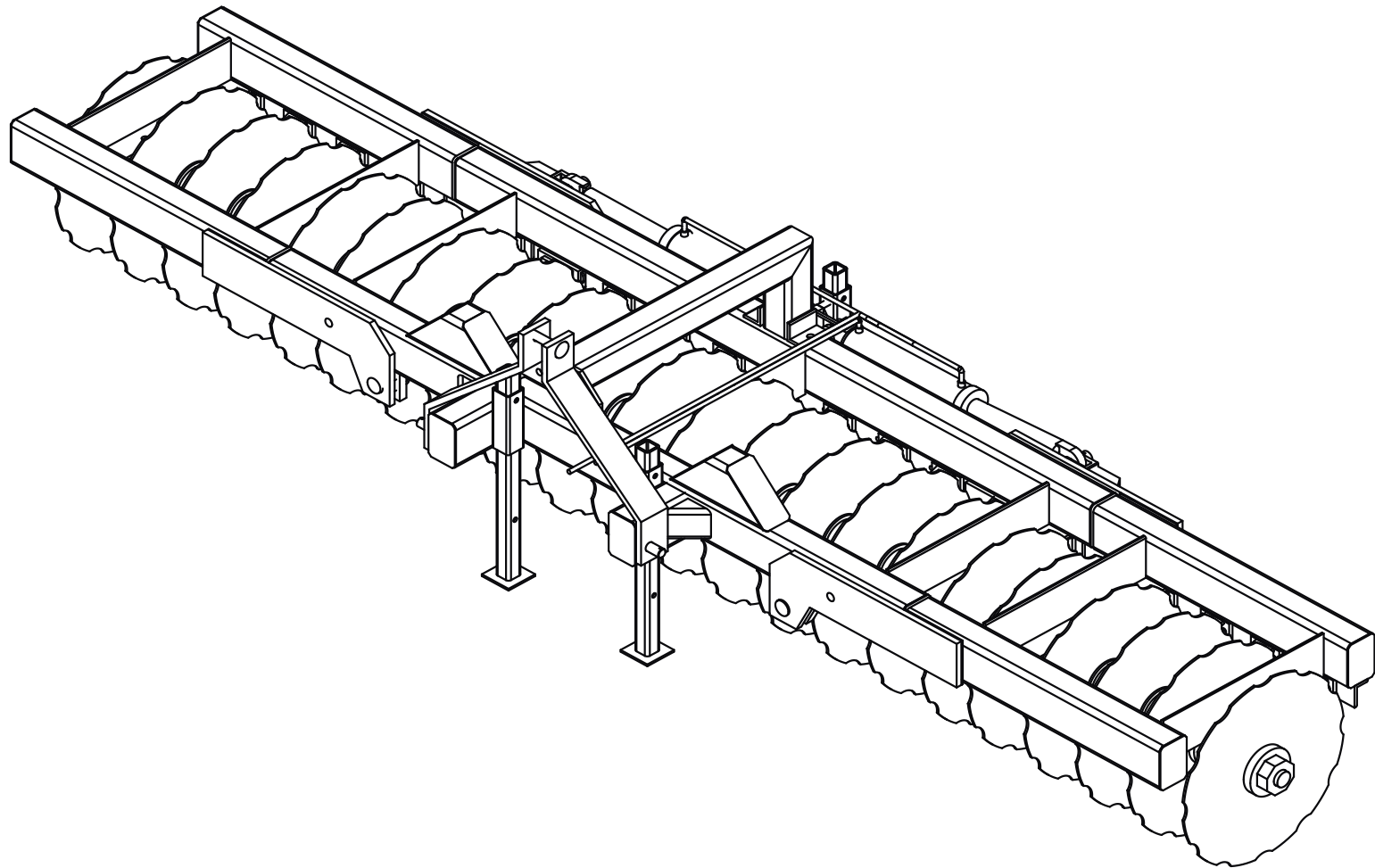

MAIN FRAME

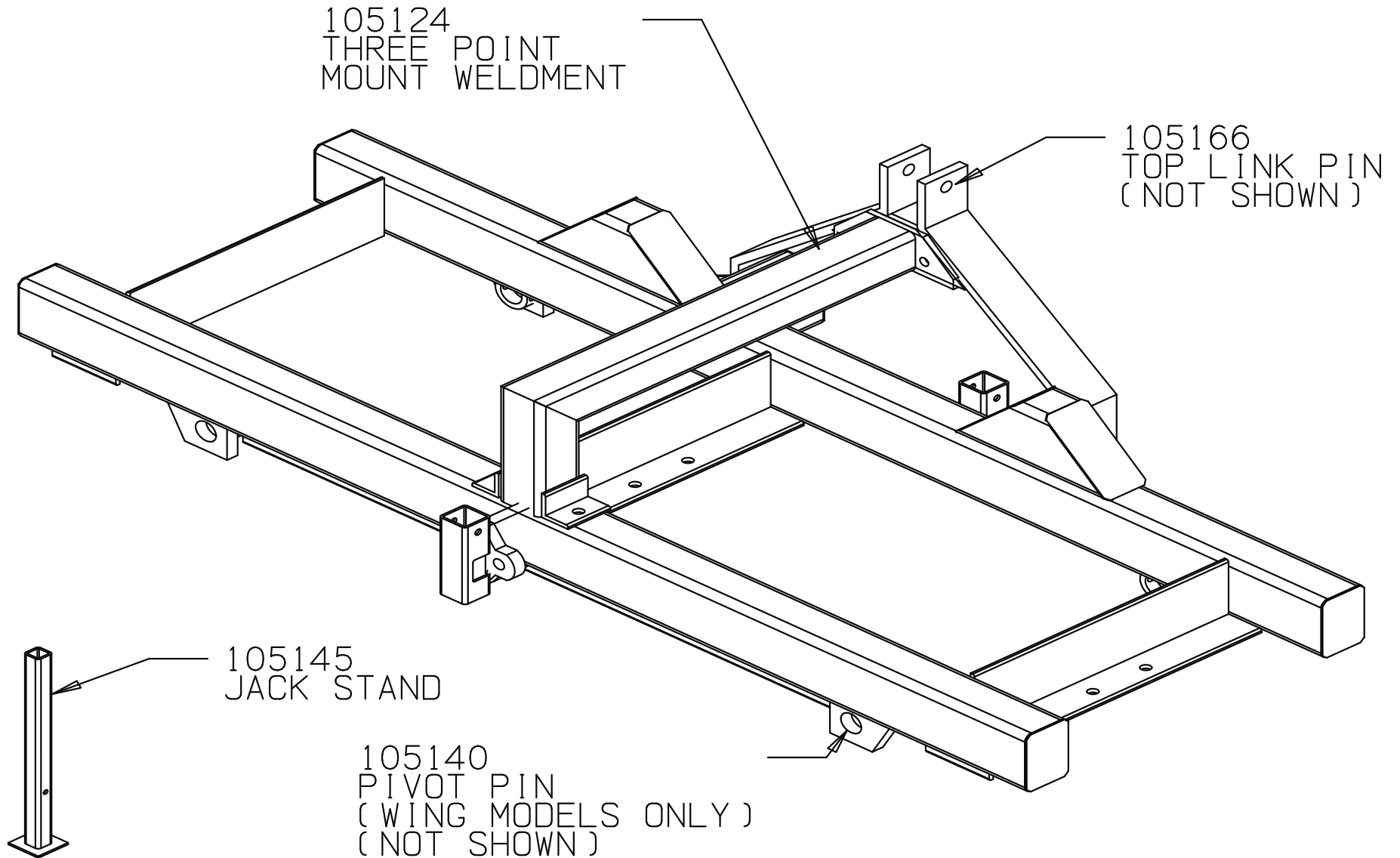

WING FRAME

14' & 16' MODELS

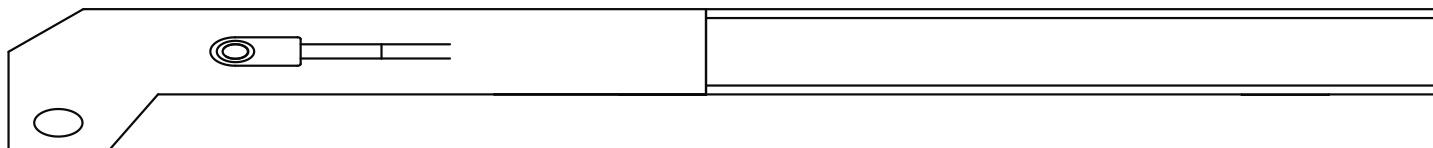
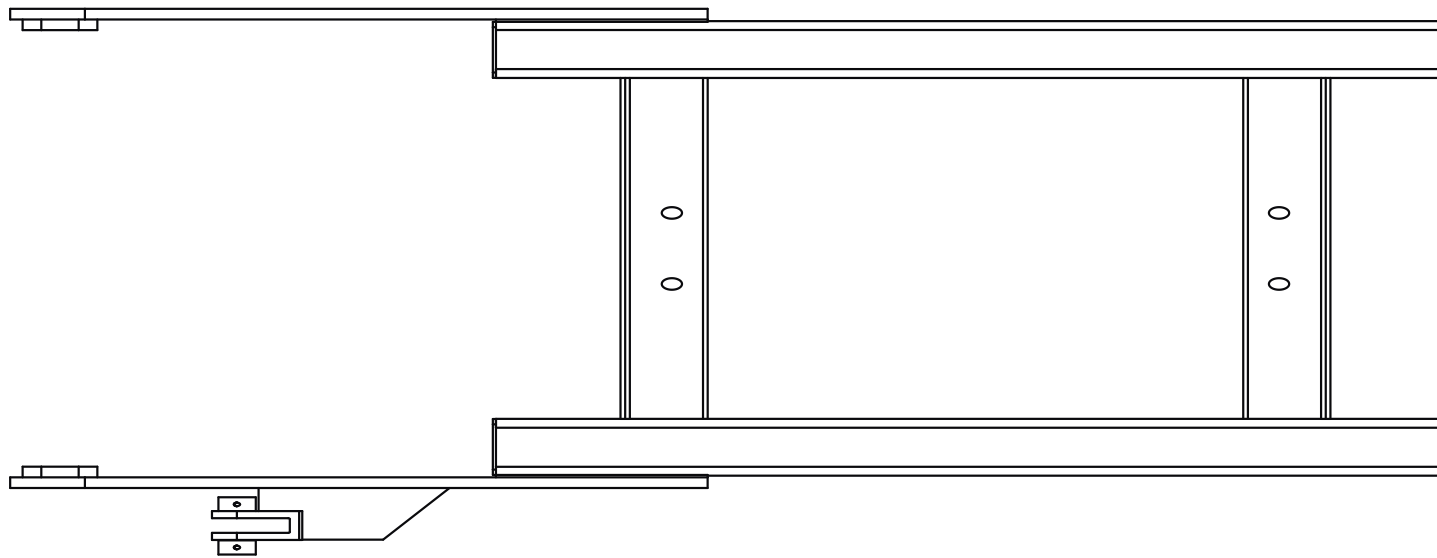

BLADE LOCATION

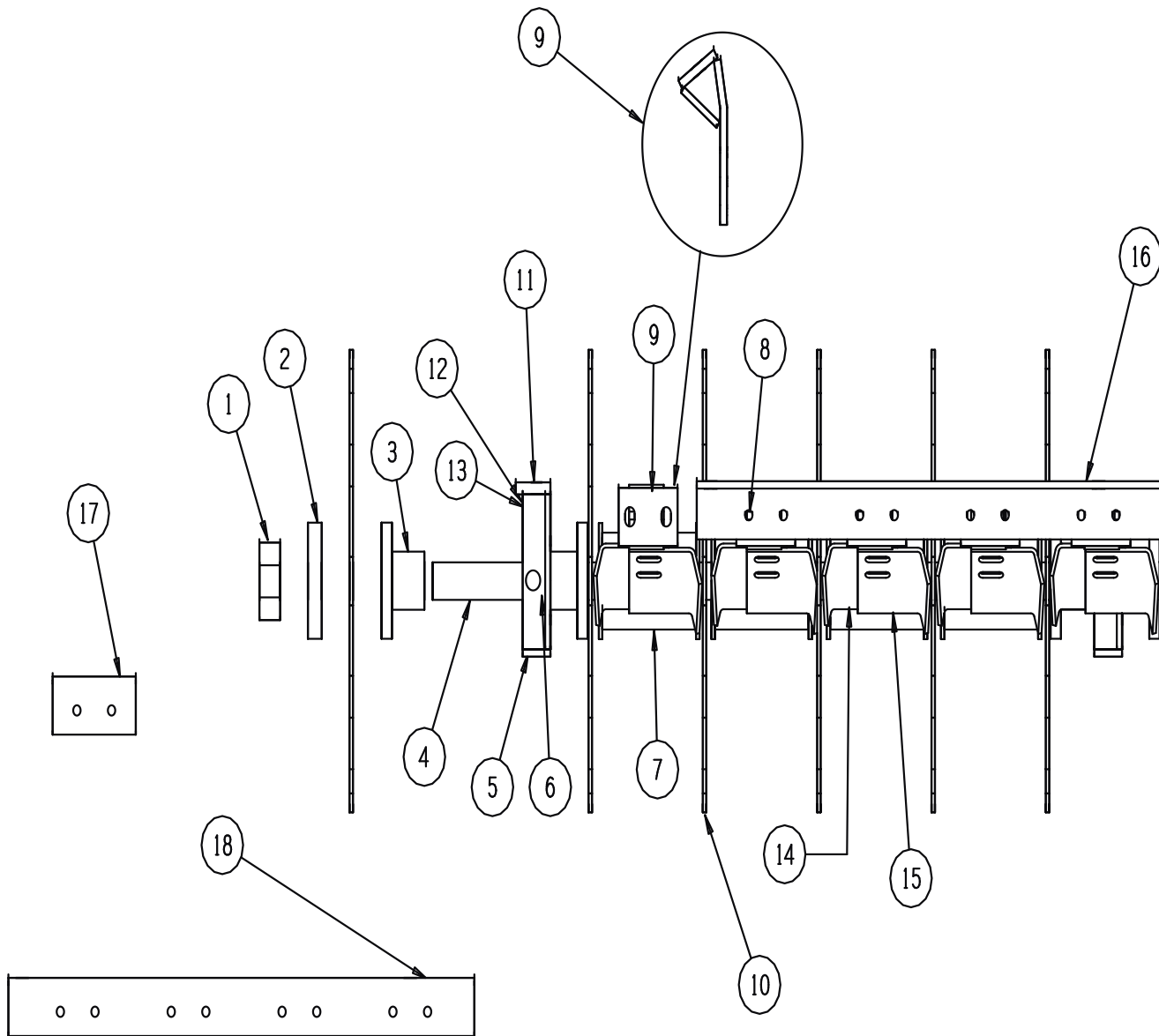

18	107232	WING SCRAPER BAR FOR 14 & 16'
17	105156	M.F. SCRAPER BAR FOR 14 & 16'
16	105155	M.F. SCRAPER BAR FOR 14 & 16'
16	107243	SCRAPER BAR FOR 8'
16	107190	SCRAPER BAR FOR 7'
16	106467	SCRAPER BAR FOR 6'
15	107700	SCRAPER RIGHT HAND
14	105150	SCRAPER LEFT HAND
13	1212	LOCKWASHER 3/4"
12	1213	NUT 3/4"
11	104338	3/4" BOLT
10	107562	COULTER BLADE
9	104822	U-CLAMP STYLE SCRAPER MOUNT
8	106084	5/8" U-CLAMP
8	1701	U-CLAMP 1/2"
7	107360	FULL SPACER 7 5/16 OAL
6	1102-214	214 BEARING
5	102082	214 BEARING BOX
4	1502	GANG SHAFT, SPECIFY LENGTH
3	107359	1/2 SPACER 8" 3 3/8 OAL
2	106923	END WASHER
1	1506	2" NUT W/SET SCREW
ITEM	PART NO.	DESCRIPTION

SCRAPERS

HOW TO TELL
RIGHT FROM LEFT!

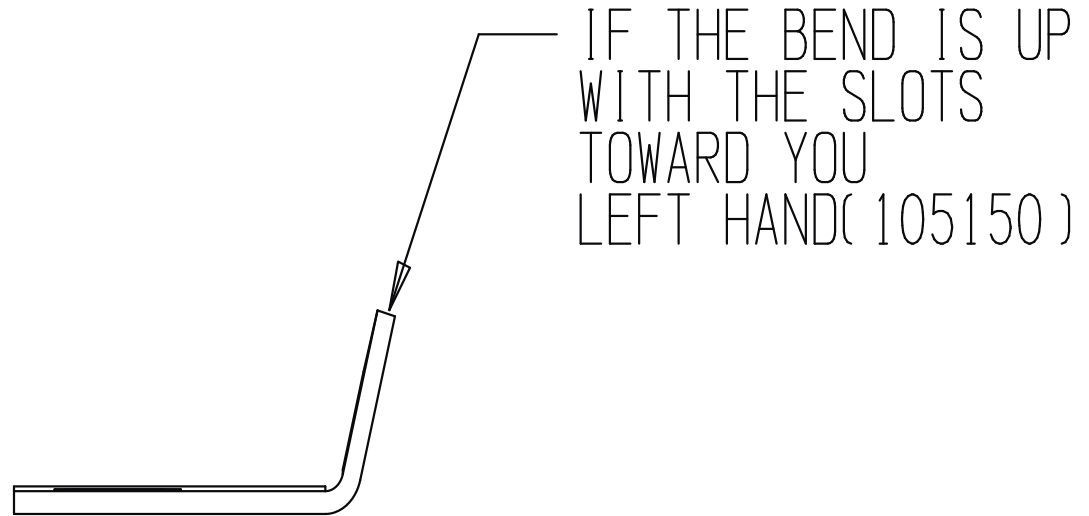
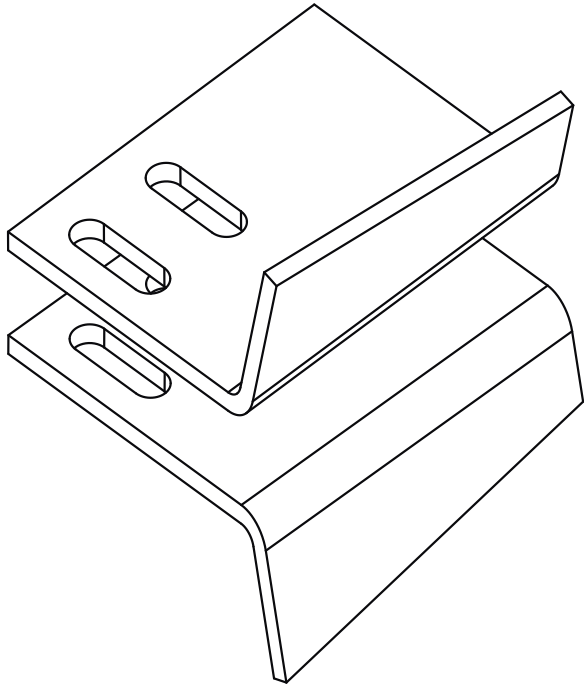

IF THE BEND IS UP
WITH THE SLOTS
TOWARD YOU
LEFT HAND(105150)

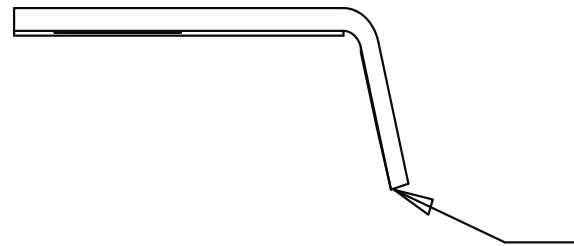

IF THE BEND IS DOWN
WITH THE SLOTS
TOWARD YOU
RIGHT HAND(107700)

12	1911	BACK UP RING
13	1910	O RING
14	1912	ROD SEAL U CLIP
15	1908	O RING
16	103244	PISTON SEAL
17	103243	WEAR RING
18	103216	SEAL KIT 3 1/2" PHASING
ITEM	PART NO.	DESCRIPTION

1	1914	NUT, CYLINDER TUBE, 3 1/2"
2	103234	HEAD GLAND, 3 1/2" PHASING
3	103242	PISTON, 3 1/2" PHASING
4	1904	LOCK NUT, SHAFT, 1-14
5	105134	CYLINDER, 3 1/2 X 14 1/2 PHASING
6	107698	BARREL ONLY
7	107699	ROD ONLY
8	104947	BOLT, 1/2 X 3"
9	104946	NUT, 1/2" TOP LOCK
10	103512	PIN, 1 X 4-1/4"
11	103225	ROD WIPER

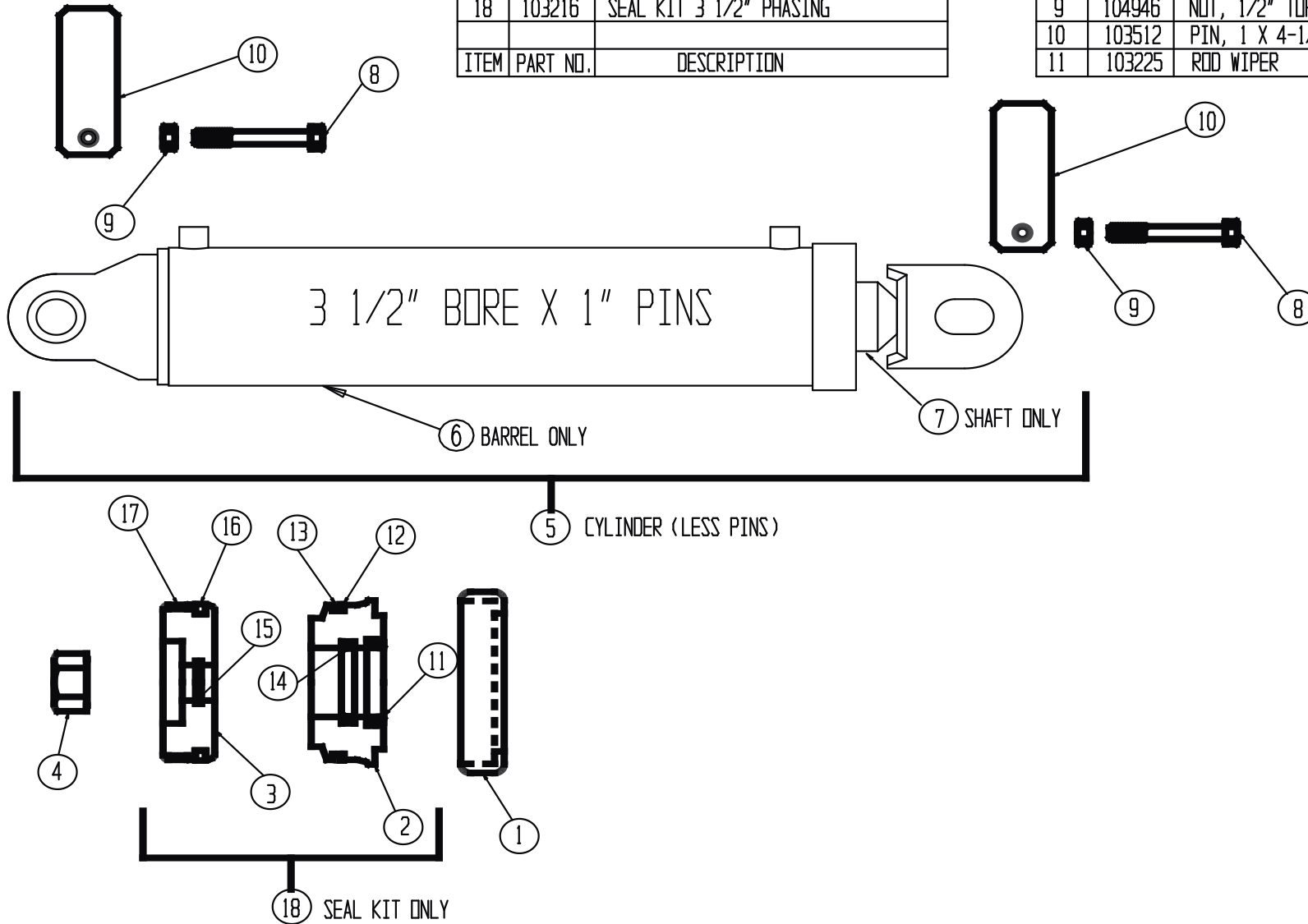

CYLINDER